

# Residential Assembled Ovens

Primavera, Napolino, Andiamo, Strada

## Forno Bravo, LLC Installation and Operating Manual

Residential Assembled Refractory Ovens, including:

Primavera 60-W-FA, Primavera 70-W-FA,  
Napolino 60-W-FA, Napolino 70-W-FA,  
Andiamo 60-W-FA, Andiamo 70-W-FA  
Strada 60-W-FA

### OUTDOOR USE ONLY

**A MAJOR CAUSE OF OVEN-RELATED FIRE IS FAILURE TO MAINTAIN REQUIRED CLEARANCES (AIR SPACES) TO COMBUSTIBLE MATERIALS. IT IS OF UTMOST IMPORTANCE THAT THIS OVEN BE INSTALLED ONLY IN ACCORDANCE WITH THESE INSTRUCTIONS.**

**IF THIS OVEN IS NOT PROPERLY INSTALLED, A FIRE MAY RESULT. TO REDUCE THE RISK OF FIRE, FOLLOW THESE INSTALLATION INSTRUCTIONS.**

Contact the factory, factory representative or a local service company to perform maintenance and repairs.

For additional copies of this manual and responses to service/maintenance questions please contact Forno Bravo, LLC.

Forno Bravo, LLC  
13525 Blackie Rd.  
Castroville, CA 95012  
(800) 407-5119  
info@fornobravo.com  
www.fornobravo.com

# Residential Assembled Ovens

Primavera, Napolino. Andiamo, Strada

## WARNING

**READ ALL INSTRUCTIONS BEFORE INSTALLING AND USING THE APPLIANCE. FAILURE TO FOLLOW INSTRUCTIONS MAY RESULT IN PROPERTY DAMAGE, BODILY INJURY, OR EVEN DEATH.**

When this oven is not properly installed, a fire may result. To reduce the risk of fire, follow the installation instructions. It is essential to use only building and insulation materials designed for the purpose.

Use proper safety equipment when installing this oven, including gloves and professional breathing masks.

Contact your local building or fire officials for clarification on any restrictions on installation of this oven in your area, or need for inspection of the oven installation.

**HOT WHILE IN OPERATION. KEEP CHILDREN, CLOTHING AND FURNITURE AWAY. CONTACT MAY CAUSE SKIN BURNS.**

**DO NOT BURN GARBAGE OR FLAMMABLE FLUIDS.**

**DO NOT CONNECT THIS UNIT TO A CHIMNEY FLUE SERVING ANOTHER APPLIANCE.**

Keep children and pets away from hot oven.

Use firewood for burning only. **DO NOT** use charcoal, pressure treated lumber, chipped wood products, sappy wood such as pine, laminated wood or any material other than dry medium or hard firewood.

**DO NOT USE** liquid fuel (firelighter fluid, gasoline, lantern oil, kerosene or similar liquids) to start or maintain a fire.

**BEWARE** of very high temperatures in the oven and use long oven gloves and mitts to handle pots and tools. **DO NOT** put unprotected hands or arms inside oven while it is lit.

Dispose of ashes using a metal shovel and place in a metal bin with a tightly fitting lid. The container should be stored on a non-combustible surface, away from all combustible materials. Ensure ashes

are completely cold before disposing of them appropriately.

**BEWARE** of flying sparks from mouth of oven. Ensure that no combustible materials are within range of oven at any time.

**DO NOT** close the oven door fully while a fire is in the oven. Closing the door fully will cut off oxygen to the fire, causing the fire to erupt suddenly when the door is removed. Always keep door tilted to allow air to circulate in the oven.

**DO NOT** use water to dampen or extinguish fire in the oven.

**DO NOT** pack required air spaces with insulation or other materials.

When the curing of the refractories is not done as part of the manufacturing process, the manufacturer's recommended curing process shall be specified. Follow the instructions for curing the oven. Failure to follow the curing schedule can cause damage to the oven, and void the oven warranty.

## SAVE THESE INSTRUCTIONS



# Residential Assembled Ovens

## Primavera, Napolino. Andiamo, Strada

Forno Bravo, LLC Ovens and Fireplaces

### THE WARRANTY

Forno Bravo, LLC, a producer and importer of quality ovens and fireplaces, warrants its refractory ovens and fireplaces (herein referred to as Product) to be free from defects in materials and workmanship on the major structural Product component (dome, firebox), for a period of five (5) years from the date of shipment. Warranty may be invalidated if Product is not correctly installed, cured, operated, and maintained according to all supplied instructions.

Forno Bravo, LLC warrants its Products' support components (floor, venting system, gas burner components, factory-installed finishes, stand, door, and accessories) to be free from defects in materials and workmanship for a period of one (1) year from the date of shipment.

### QUALIFICATIONS TO THE WARRANTY

The complete Product Warranty outlined above does not apply under the following circumstances:

- (1) The Product was not installed in accordance with Forno Bravo installation instructions and local building codes.
- (2) This Warranty does not apply to any hairline cracking caused by over-firing or the failure to follow a proper curing schedule. See Product Manual for a detailed explanation of this curing schedule.
- (3) The Product has been subjected to non-standard use, including but not limited to, tossing or throwing firewood into the oven with force, addition of non-approved appliances or burners, burning fuels with abnormal burning characteristics, including: driftwood, coal, plywood, and wood products using a binder that may burn at excessive temperatures, causing damage to the Product.
- (4) The Product has been subjected to icing or wet-mopping the oven while it is still heated (which can cause damage/cracking to the oven floor.) Improper chemicals or liquids have been used to clean or sanitize the interior of the oven.
- (5) This Warranty does not cover damage caused by storing any materials on the top of a fully assembled oven or on the dome of an unfinished kit oven.
- (6) This Warranty does not apply to normal wear and tear of the Product, or on parts that

would be worn or replaced under normal conditions, including:

- (a) Normal, minor cracking due to expansion and contraction stress relief in the refractory materials of either the dome or floor tiles.
- (b) Discoloration of exterior finishes in areas repeatedly exposed to smoke, as this is considered normal wear on wood fired pizza ovens and fireplaces.
- (7) This Warranty does not cover damage to, or failure of the Product, resulting from natural or other catastrophes, such as flood, fire, wind, or storm.
- (8) In the event that the UL Listing Plate (if applicable) has been removed, altered, or obliterated.

### LIMITATION ON LIABILITY

It is expressly agreed and understood that Forno Bravo's sole obligation, and Purchaser's exclusive remedy under this Warranty, and under any other Warranty, expressed or implied otherwise, shall be limited to replacement, repair, or refund up to the original purchase price of the Product, excluding shipping costs, as specified above. Such liability shall not include, and Purchaser or other third parties, specifically renounces any rights to recover special, incidental, consequential, or other damages of any kind whatsoever, including, but not limited to, injuries to persons or damage to property, loss of profits or anticipated profits, damage to business reputation or goodwill, all costs incurred receiving, unloading, moving at your location, and installing Forno Bravo Products, or loss of use of the Product.

In no event shall Forno Bravo be responsible for any incidental or consequential damages caused by defects in its Products, whether such damage occurs, or is discovered before or after replacement or repair, and whether or not such damage is caused by Forno Bravo. The duration of any Warranty with respect to this Product is limited to legitimate claims received within the duration of the foregoing Warranty.

Warranty of replacement parts or Product shall only be from the original purchase date of Product, not the date of repair or replacement covered under this Warranty. Parts to be replaced under the Warranty will be repaired or replaced with new or functionally sound parts at Forno Bravo's option.

Note: Some states do not allow the exclusion or limitation of incidental or consequential

damages, or the duration of an implied warranty, so the above exclusion or limitations may not apply to you.

### INVESTIGATION OF CLAIMS AGAINST WARRANTY

Forno Bravo reserves the right to investigate any and all claims against this Warranty and to decide upon method of settlement.

Before any Product is returned, Forno Bravo, or its authorized representative, must provide Purchaser with written return authorization and instructions for preparation of the shipment. Failure to properly package Product for return may result in Purchaser being billed by Forno Bravo. Forno Bravo reserves the right to bill Purchaser for return freight if Product was found to be damaged through negligence or Warranty was voided, as outlined in this Warranty. Reference your original Terms of Sale Agreement for additional details.

### DEALERS HAVE NO AUTHORITY TO ALTER THIS WARRANTY

Forno Bravo's employees and dealers have no authority to make any Warranties, nor to authorize any remedies in addition to, or inconsistent with, those stated above.

### HOW TO REGISTER A CLAIM AGAINST WARRANTY

In order for any claim under this Warranty to be valid, Forno Bravo must be notified of the claimed defect by either:

- Telephone at 1-800-407-5119, or outside the U.S. at +1 (408) 317-0124,
- Writing to Forno Bravo, 13525 Blackie Rd, Castroville, CA 95012, or
- Please fill out our easy-to-use [technical support form](#) for claims against the warranty.

All claims against this Warranty should include the Product model, original invoice number, date of installation, a description of the defect, photographs of the area of concern, and a full description of the circumstances giving rise to the Warranty Claim, if known. Please examine all of the contents of your delivery as soon as possible after receipt and inform Forno Bravo within ten (10) days if any items are missing, incorrect, or damaged.

Updated 4/5/21



# Residential Assembled Ovens

Primavera, Napolino, Andiamo, Strada

## Table of Contents

1. About Your Oven .....	5
2. Included Items .....	6
3. Optional Oven Tools .....	7
4. Moving Your Oven .....	7
5. Stand Assembly .....	7
6. Oven Clearances .....	8
7. Curing Your Oven .....	9
8. Firing and Operation .....	9
9. Oven Care and Maintenance .....	10
10. How Your Oven Works .....	10
11. Types of Wood Fired Cooking .....	12
12. Oven Management .....	15
13. Pizza Baking .....	17
Appendix 1: Cucina Stand Assembly .....	19
Appendix 2: Dimensions .....	20



# Residential Assembled Ovens

Primavera, Napolino. Andiamo, Strada

## 1. About Your Oven

Your Forno Bravo Residential Assembled Wood Oven is made by hand, with care, in the U.S., using traditional methods and the highest quality modern refractories and insulators.

**PLEASE READ THIS ENTIRE PAGE. IT CONTAINS IMPORTANT INFORMATION THAT WILL HELP KEEP YOUR OVEN OPERATING OPTIMALLY. FAILURE TO FOLLOW THESE INSTRUCTION CAN DAMAGE THE OVEN AND POTENTIALLY VOID THE OVEN WARRANTY.**

### *Variations in Finish*

Because your oven is handmade, you will see variations in the exterior finish and paint, and in the cooking tiles— which are hand cut to fit your oven. These variations are normal. We think these ovens offer authentic handmade charm, and we hope that you agree with us.

### *Curing*

Unless your oven was cured as part of the manufacturing process, always follow the curing schedule provided with your residential assembled oven. It is vital that you bring your oven up to heat slowly in order to not damage the oven dome and vent material. In the event that the inside of your oven gets wet, follow the Curing Schedule to slowly dry it out. You should also bring your oven up to heat slowly after any period of rain and/or the oven not being used -- such as the first firing in the spring.

### *Soot*

Over time, as is the case with any wood oven, the top of the opening to your oven will become black with soot. While your oven's vent and terracotta chimney system does an excellent job of drawing

smoke and hot air out of the oven chamber, soot is an unavoidable part of any wood oven. You can occasionally clean the oven opening with soap and water, or you can allow the opening to naturally become black. You may also choose to occasionally re-paint the oven opening. For a touch up kit, please contact Forno Bravo. Each strategy works equally well.

### *Oven Care*

Your oven enclosure is sealed and painted to withstand outdoor weather conditions, including rain and snow. But you must take care to ensure that water does not enter the oven cooking area. If you choose to leave your oven outside permanently, always place the oven door tightly across the oven opening, and place the cap on top of the chimney.

### *Hairline Cracks*

Small hairline cracks in your oven dome or vent can be a normal part of the heat up/cool down (expansion/ contraction) cycle that all wood ovens experience. These small cracks will not impact how well your oven cooks or how long it will last, and a majority of minor cracks can be ignored. If you have any questions or concerns, please contact Forno Bravo.

### *Water*

Water can damage the inside of your oven. Please ensure that no water enters the oven chamber, either through the oven door opening or through the vent. During rain and other wet or damp weather conditions, use the provided chimney cap to stop water from going down the chimney, and place the provided metal door at the oven opening to stop water from entering through the door. Do not set the oven at a backward angle, where water could enter the oven and cause damage.



# Residential Assembled Ovens

Primavera, Napolino. Andiamo, Strada

## 2. Included Items

- Refractory wood oven and chimney;
- Metal stand (except no stand version). Some assembly required;
- Steel door with dial thermometer;
- Chimney cap;
- Forno Bravo CD ROM with cooking and operation eBooks.

### Optional Accessories (not included with the oven)

- Pizza peels and oven tools;
- Infrared thermometer;
- Oven bakeware.



Andiamo



Strada on a stand



Primavera on a stand



Napolino on a stand



Primavera with no stand

# Residential Assembled Ovens

Primavera, Napolino, Andiamo, Strada

## 3. Optional Oven Tools

Forno Bravo provides optional oven tools that will make your wood fired oven more fun and functional. To see the full selection visit our online store at: [https://www.fornobravo.com/product-category/oven-tools-cooking-accessories/?post\\_type=product](https://www.fornobravo.com/product-category/oven-tools-cooking-accessories/?post_type=product)

## 4. Moving Your Residential Assembled Oven

### TAKE CARE WHEN LIFTING AND MOVING THE

**OVEN.** The Residential Assembled ovens weigh roughly 450-600 lbs., and require at least four to six strong men to lift and move. We recommend using a forklift, crane or other mechanical equipment to move the oven and set it in place.

Oven	Weight (lbs.)
Primavera 60	450
Primavera 70	600
Napolino 60	450
Napolino 70	600
Andiamo 60	450
Andiamo 70	600
Strada 60	315

**DO NOT TURN THE OVEN ON ITS SIDE.** The Residential Assembled ovens are not designed to be turned on their side and you will cause significant damage to the oven if you do so.

**Be sure that you have enough manpower to safely move the oven and set it in place. Failure to do so could cause serious bodily injury.**

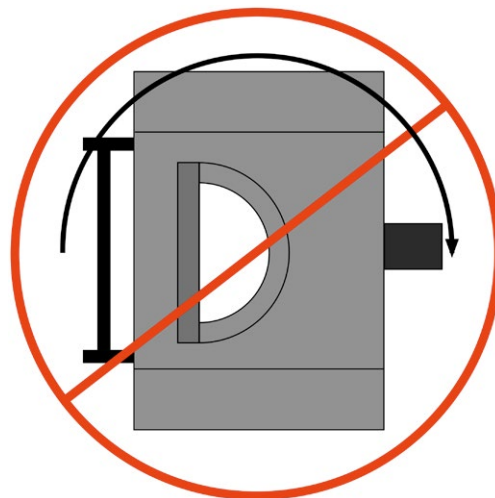

The best way to move and lift the oven using manual labor is to slide two or three pieces of 2x4 lumber under the oven and have the movers lift from both sides.

## 5. Stand Assembly

Residential Assembled ovens ordered with a stand are built into the stand tray and are shipped with the the stand legs, support brackets, and wood storage shelf.

Residential Assembled ovens ordered without a stand are designed to be placed on a customer provided stand, a Forno Bravo Cucina Stand or BBQ island.

**TAKE CARE WHEN ATTACHING THE LEGS AND WOOD STORE TO THE OVEN. The oven is very heavy. Be sure that you have enough manpower to safely place the oven in the stand. Failure to do so could cause serious bodily injury.**

# Residential Assembled Ovens

Primavera, Napolino. Andiamo, Strada

## Attaching the Stand



Place two or four pieces of 2x4 lumber under the oven. Then with at least five people, lift the oven using the 2x4's



Attach the stand legs with the included bolts.

## 6. Oven Clearances

It is essential to maintain clearance space between the oven components and any combustible material, such as walls and ceilings. Failure to maintain these clearances can result in fire.

## Combustible Wall Clearance

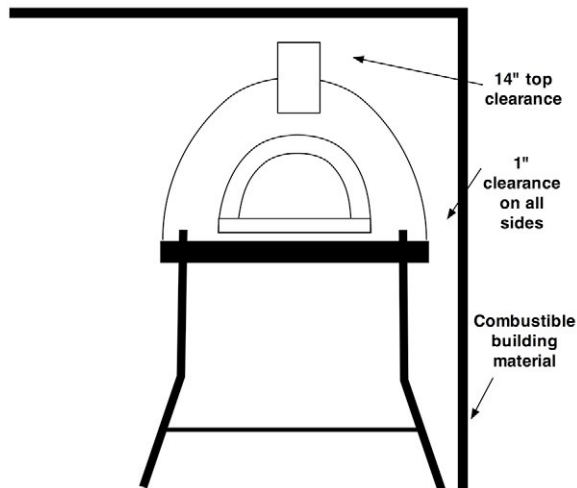

The oven must have a minimum 1" (25 mm) clearance to combustibles from all sides, and 14" (356 mm) clearance to combustibles from the top.

If building materials will contact the oven, they must be completely noncombustible. Please note that standard drywall (or sheet rock) is considered a combustible.

If the oven is built into a permanent enclosure, the area directly above the doorway and 6" (152 mm) to each side of the doorway must be covered with non-combustible material.

Non-combustible construction, such as a decorative stone covering, may contact the oven and must then maintain 1" (25 mm) clearance to combustibles.

If the space between the legs of the stand is used for wood storage, it is recommended that it be a covered container or box to prevent the possibility of sparks or embers from making contact with the stored wood. An 8-1/2" (eight and one-half inch) air space clearance is required between the bottom of the oven and any wood storage container.





# Residential Assembled Ovens

Primavera, Napolino. Andiamo, Strada

## Floor Hearth Extension

The minimum floor hearth extension areas from the oven door opening to combustible floors are as follows:

- 30" (762 mm) to each side of the door opening
- 36" (914 mm) in front of the door opening

## 7. Curing Your Oven

Unless your Residential Assembled oven was cured as part of the manufacturing process, you will need to cure the oven. Although it may appear that your oven is dry, there is moisture in the oven dome, cooking floor, mortars and concrete that must work its way out. It is important that you cure your oven slowly, by building a series of five increasingly larger fires, starting with a low temperature. These fires bake the moisture out of your oven slowly, without creating steam that can damage the oven pieces.

If you begin building large fires in your oven right away, you will compromise your oven's longevity, and cause damage, including cracking.

For an accurate reading of the oven's surface temperatures, you can use the optional digital infrared thermometer.

Day 1. Maintain a fire temperature of 300°F throughout the day and as long as possible into the evening. Close the oven door at the end of the day.

Day 2. Repeat at 350°F.

**Important Note:** While it is difficult to maintain consistent, low temperature fires, it is critical for proper curing that you do not go above these temperatures during the first two days. The temperature of the oven will vary at different spots—particularly at first. Do not exceed the recommended temperature at the hottest spot, typically the top of the dome directly above the fire.

Day 3. Repeat at 400°F.

Day 4. Repeat at 450°F.

Day 5. Repeat at 500°F.

Close the oven door every evening to preserve dryness and heat.

---

**Small hairline cracks can occur with normal heating and cooling. They will not affect the performance or longevity of the oven. If cracks of 1/8" or more develop, contact Forno Bravo.**

---

## Important Notes

**Use solid wood fuels only.** DO NOT use charcoal, pressure treated lumber, chipped wood products, sappy wood such as pine, laminated wood or any material other than dry medium or hard firewood.

**Do not use products not specified for use with this oven.**

DO NOT USE liquid fuel (firelighter fluid, gasoline, lantern oil, kerosene or similar liquids) to start or maintain a fire.

Never use water to lower the temperature inside the oven, or to extinguish the fire.

## 8. Firing and Operation

Start your fire in the center of the oven cooking floor using a taste-free, odor-free fire starter and dry kindling. Build your fire up slowly, adding wood to the back and sides as the fire grows.

Continue to add wood until the oven reaches the desired temperature. Then, move the fire to one side and brush the oven floor. Only use a copper or brass brush, and do not use steel wire brushes, natural fiber brushes or wet clothes to clean the oven floor.



# Residential Assembled Ovens

Primavera, Napolino. Andiamo, Strada

You can monitor your oven temperature using an optional digital infrared thermometer.

DO NOT over fire your oven, or build a fire where flame exits the oven door opening.

BEWARE of very high temperatures in the oven and use long oven gloves and mitts to handle pots and tools. DO NOT put unprotected hands or arms inside oven while it is lit.

BEWARE of flying sparks from mouth of oven. Ensure that no combustible materials are within range of oven at any time.

DO NOT close the oven door fully while a fire is in the oven. Closing the door fully will cut off oxygen to the fire, causing the fire to erupt suddenly when the door is removed.

Never use gasoline, gasoline-type lantern fuel, kerosene, charcoal lighter fluid, or similar liquids to start or “freshen up” a fire in the oven. Keep all such liquids well away from the oven when in use.

Keep the oven door opening free of all combustible materials when the oven is in operation.

Disposal of Ashes. Ashes should be placed in a metal container with a tight-fitting lid. The closed container of ashes should be placed on a non-combustible floor, or on the ground, well away from all combustible materials pending disposal. When the ashes are disposed by burial in soil, or otherwise locally dispersed, they should be retained in the closed container until all cinders have thoroughly cooled.

Wood can be safely stacked in the area under the oven.

---

For more information on Oven Management and Wood Fired Cooking, refer to the Forno Bravo Wood Fired eCookbook Series—including Wood Fired Cooking, Wood Fired Pizza and Wood Fired Hearth Bread—included on the CD ROM provided with this oven.

---

## 9. Oven Care and Maintenance

Your Residential Assembled oven enclosure is sealed and painted to withstand outdoor weather conditions, including rain and snow. But you must take care to ensure that water does not enter the oven cooking area. If you choose to leave your oven outside permanently, always place the oven door tightly across the oven opening, and insure the cap is in place on top of the chimney.

Your oven requires very little on-going maintenance or cleaning. The oven operates at very high temperatures, which acts as an automatic “self-cleaning” mode, burning off all spilled or stuck-on foods.

If stuck-on food is a problem during cooking, you can remove it with the optional brass oven brush.

Clean the ashes out of your oven before you light a new fire. Old, cold ashes will get in the way of food baking.

## 10. How Your Oven Works

Wood fired ovens use heat retained in the refractory dome and cooking floor, along with the option of a live fire or hot coals to create a range of different cooking environments. Your Residential Assembled oven can work with a live fire, hot or warm coals and retained heat.



# Residential Assembled Ovens

Primavera, Napolino, Andiamo, Strada

It is this unique cooking ability that let's you bake Italian pizza, hearth bread and great roasts in your oven, and that makes wood fired cooking unlike any other type of cooking.

## Live Fire

When cooking with a live fire, your Forno Bravo oven cooks simultaneously in three ways, as shown in the three graphics below.

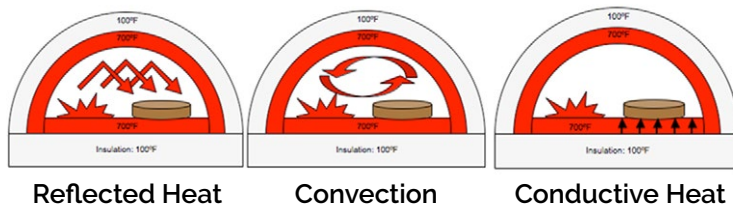

Reflected Heat

Convection

Conductive Heat

With reflective heat, flame from a live fire is bounced off the dome onto your food. This reflective heat cooks food, such as pizza, and also recharges the cooking floor, putting heat back into the floor to replace heat that is lost through cooking.

Because your Forno Bravo oven breathes, drawing in cold air through the lower half of the oven opening and exhausting hot air out the top half of the opening, it is constantly moving hot, moist air across the top of your food. While modern convection ovens use fans and heat coils to move hot, dry air within the oven, nothing can compare with natural convection.

Finally, heat stored in the cooking floor is transferred directly into food that is set on top of it. This is true for bread and pizza, which are set directly on the cooking floor, as well as for pots and pans which are placed on it.

## Hot or Warm Coals

There are many dishes that do not need, or want, the high heat of a live fire and a very hot 700°F oven. For cooler styles of cooking, let your fire die down and allow your oven to cool. You can use the heat of the coals and a hot oven to roast, brown, sear, and grill, and to ensure that your oven will retain enough heat for longer periods of cooking. You can use hot or warm coals either on the side of the oven, or directly under your food—as shown below.

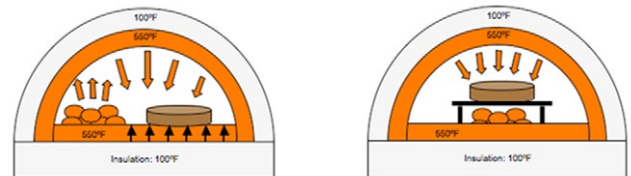

## Retained Heat

For baking bread and other dishes at temperatures where you would normally cook in a conventional oven, your oven will cook for hours with retained heat. You can rake out the coals from the fire, and then close the oven door to let the oven temperature moderate.

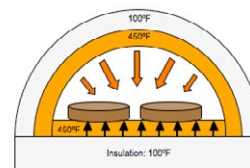

With this type of cooking, you can bake bread, desserts and small roasts, and as the oven temperature falls, you can slow cook beans, soups and stews, and long-cooking meats and ribs.

# Residential Assembled Ovens

Primavera, Napolino. Andiamo, Strada

## 11. Types of Wood Fired Cooking

Your Forno Bravo oven is capable of an almost endless variety of cooking styles. With almost all types of cooking, you should bring your oven fully up to heat, and then prepare it for the type of cooking you want to do by moving the fire and coals to one side of the oven, and then letting the oven temperature reach the range where you will be cooking. How long you fire your oven depends on how much cooking you will be doing, and how long you want your oven to hold its heat.

Remember that you can only take out heat from the oven that you put in. If you are going to be cooking a lot of pizza for a large party, or baking lots of bread or a large roast, fire your oven longer. If you are making pizza for the family for a mid-week meal, you can fire your oven for a shorter time—typically only until the dome goes white.

The main cooking styles are:

### *Fire-in-the-Oven Cooking*



Fire-in-the-oven cooking (650°F and up) is used for baking pizza, pizza-like flatbreads and certain types of appetizers, all of which cook in a couple of

minutes. Your Forno Bravo Pizza Oven can be pizza-ready in about 45 minutes. The goal with this type of cooking is to completely fill the floor and dome with heat, build up a large sized bed of coals and maintain a large fire where the flame reaches to top of the dome.

There are two ways to know that an oven is ready to cook pizza. First, when the oven dome itself has gone clear, and there is no visible black soot. At this point, you should move the fire to one side, while continuing to maintain a large fire going with the flame reaching the middle of the oven.

Alternatively, if you are using an infrared thermometer, the floor should read approximately 650°F-700°F. Pizzas are baked right on the floor next to the fire. Leave the oven completely open, and add one piece of wood every 15-20 minutes to maintain a large flame.



---

**For a visual description of how your Forno Bravo oven absorbs, holds and uses heat to cook, see our Wood Fired Cooking eBook.**

---

# Residential Assembled Ovens

Primavera, Napolino. Andiamo, Strada

## ***Roasting (at higher heat than baking)***

When you want to sear meats, brown vegetables or casseroles before covering them with a lid or with liquid, or you want a dish to cook completely before the outside burns or becomes too brown, you should use a roasting temperature of between 600°F and 450°F. This range is lower than for high heat fire-in-the-oven pizza cooking, but higher than for traditional baking. In order to roast, first bring your oven up to pizza temperature, and then allow it to drop in temperature and the fire to burn down but not out. Push the coals to one side.



The fully fired oven combined with a low fire, enables you to sear and brown dishes, and then allows the oven to slowly drop in temperature for longer cooking. There should be no visible black on the dome, a medium sized bed of coals and a small flame of 2"-4" high. The door may be left off for shorter roasting times (under one hour) or positioned inside the arch opening to help regulate the heat for hours of roasting. Add small pieces of wood as needed to maintain temperature.

## ***Baking (at conventional oven temperatures)***

Baking (500°F and lower) is used for baking bread, desserts, smaller roast meats, beans and legumes, and pasta dishes. After fully firing your oven, carefully rake out the hot coals and brush out the oven. If you

wish, you can swab the deck with a damp, not wet, towel. As the temperature falls, your oven will cook gently and consistently using the heat retained in the oven dome and floor.



With this type of cooking, you can bake either one fully loaded batch of bread, or multiple batches of different types of bread, but with smaller quantities.

---

**Read the Forno Bravo Wood Fired Bread eCookbook for more information on bread baking techniques and recipes.**

---

## ***Grilling***

Your wood fired oven makes a great grill. By raking a layer of hot coals across the cooking floor at the front



# Residential Assembled Ovens

Primavera, Napolino. Andiamo, Strada

of your oven, and sliding in a free standing cast iron grill into the oven, you can enjoy wonderful grilling – with top and bottom heat. Meats and vegetables get very good grill marks that seal in moisture, giving you food that is crisp and not dried out. With heat from the grill itself, from the coals below it, and the heat radiating from oven dome above, your brick oven can cook faster than a traditional grill, leaving your food more moist and tender.

## ***Browning***

Your Forno Bravo oven reflects heat down from a live fire to brown and sear foods. You can sear meats, before adding them to casseroles to cook, and you can brown vegetables as evenly and quickly as you can with the broiler in your conventional oven. If your recipe calls for browning multiple batches of vegetables, such as Eggplant Parmesan or Ratatouille, you can spread out and use your entire cooking floor to quickly do the job.



## ***Sautéing***

If your recipe calls for sautéing something (anything), such as onions and garlic, celery and carrots, or ground beef, you can use a metal pan to do the job in your Forno Bravo oven. Preheat the pans for a minute or two, and then add your olive oil, and return the pan for a few seconds. Add your chopped vegetables,

or anything else you need to sauté, and return the pan for a few minutes. You can either slightly sauté vegetables until they are soft and translucent, or leave them in a while longer to brown the vegetables and build up the browned bits that you can reduced into a sauce with a splash of wine. You can leave your pan in even longer to caramelize your onions.

## ***Combination Cooking***

Many wood fired oven dishes, such as Coq au Vin, Chicken Fricassee and baked vegetable dishes can be cooked in a single pan, without having to use your conventional oven cook top. Add your ingredients in layers, sautéing and browning them as needed. Add your liquid ingredients at the end, and cover your pan to bake. This not only keeps you out of the kitchen and reduces the number of pans you have to clean, it also holds all of the flavors of your ingredients in your pan and in your food – where you want them.

## ***A Clay Pot in a Brick Oven***

Use a covered clay pot, such as a Romertopf or Forno Bravo terracotta pot, in your Forno Bravo oven to roast a moist and tender chicken. Fully fire your oven, let the temperature fall to about 650°F, and then add your covered dish. Your roast stays moist for a long time, you have more room for error between a chicken that is not quite done, or is already dried out.



# Residential Assembled Ovens

Primavera, Napolino. Andiamo, Strada

## ***Warming and Melting***

You can place any type of dish, cup or pan at the mouth of your oven to warm a sauce or stock, melt butter, and make flavored olive oils. Try putting 1 Tbs. of fresh rosemary into a quarter cup to olive oil and leave at the entry to your oven to warm through. You can use the flavored oil for dipping, or for vegetable dishes.

## ***Bakeware to Avoid***

White porcelain pans tend to crack in a wood fired oven.

Be careful with terracotta-looking pans mass-produced in Asia. They might not withstand the temperature of your wood fired oven. You probably would not worry about the cost of the pan, but if it cracks, it probably will ruin your meal.

Be careful with any ceramic pan that you would be sad to lose. Better safe than sorry. The combination of high heat, flame and being moved around with a pizza peel can be rough on any pan.

## ***Making Wood Coals for External Grilling***

Nothing tastes better than food cooked over real wood coals, and your brick oven is an efficient source of those coals.



That is why many Italian outdoor kitchens include an attached open grill, which can be used either with its own fire, or with coals from the brick oven. If you have a conventional charcoal grill, use your Forno Bravo oven shovel to move hot coals to your grill.

---

**Finally, try experimenting with different pot and pans. A grill pan pre-heated in your oven gives your food nice sear marks, and terracotta pans and steel pans give roast potatoes a different texture and flavor.**

---

## **12. Oven Management**

Remember to leave enough time to fully fire your oven before you need it for cooking. If you are cooking just for your family, or for an after work meal, you can fire your oven for as little as 40 minutes, and still easily bake three or four pizzas. If you are holding a larger party, or want to have retained heat for other baking, fire your oven for 90 minutes, or longer.

Build your fire in the center (left to right and front to back) of the oven using 7-9 sticks of dry kindling, one to two odor-free, non-toxic fire starters, and two to three pieces of seasoned medium or hardwood. Alternatively, you can light your fire with a butane torch. It can be easier and faster than the traditional match or lighter. Try to avoid wax and sawdust fireplace starters, as they could leave a taste in your food.



# Residential Assembled Ovens

Primavera, Napolino. Andiamo, Strada

Once the fire gets going, add 2-3 pieces of wood so that the flame reaches the center and front of the dome, without lapping too far out of the oven opening. Use seasoned wood that is roughly 3"-4" in diameter, and roughly 12" long. Your firewood should not smolder or smoke before catching fire, and should burn easily and quickly. Once the fire is well established, continue adding more wood, and wait for about 20 minutes.

After about 20 minutes, a small spot at the top center of the oven dome should start to turn clear (or white) and then begin expanding outward. This "whitening" is the sign that dome is reaching the desired cooking temperature.

This change occurs when the carbon accumulated on the oven dome reaches about 700°F, and turns from black to clear.



Once the whitening has started, begin building the fire toward the walls of the oven by adding pieces of wood on either side of the fire, and in the back. This wider fire will help drive the necessary heat across the entire cooking floor, and evenly spread heat across the dome. Within a few minutes, you will see the whitening spreading across the dome to the sides.



After roughly 45 minutes, the entire cooking dome will turn clear, and the cooking surface will have reached the desired 700°F+ for cooking pizza. Push the fire to the side of the oven, brush the floor, and you are ready to start baking pizzas.

Use a copper/brass brush designed for use with a wood oven. Do not use a steel BBQ grill brush, which will scratch your cooking floor.

Also, we do not recommend using a damp towel to clean the floor. The cool, wet towel will take heat out of your cooking floor, and it is not necessary. A well-made pizza oven brush will be able to get all of the ashes off the part of the floor where you will be making pizza. This is a different strategy that when you are baking wood fired bread, where the towel is good both for cleaning the floor and for moderating the floor temperature for bread.

You want a live fire the entire time you are cooking pizza. The heat of the fire bounces off the dome and down to help cook your pizza and also to restore heat to your cooking floor. Your flame should roughly reach the apex of your dome, or even past it.

Add a new piece of wood every 15-20 minutes when you are cooking pizza. Your fire should be hot enough where a 2-3" diameter piece of wood will quickly combust and add heat to the oven and flame in the dome.





# Residential Assembled Ovens

Primavera, Napolino. Andiamo, Strada

## ***Vera Pizza Napoletana***

A quick word on oven temperature. There has been a lot of discussion on oven temperature ever since Forno Bravo first translated the original Verace Pizza Napoletana document a number of years ago. Since then we have received many emails and phone calls asking our opinion on cooking temperature, and whether the 900°F mentioned in the document is essential.

First, it is worth noting that there are multiple documents and web sites that mention Pizza Napoletana, and that there really is not a “correct” temperature. The VPN association in the U.S. says 800°F, and other Italian sites mentions 750°F.

Our thinking is that there is more to temperature than a single number. As a pizzaiolo, you have to manage dome and cooking floor temperature, as well air temperature and the heat of your flame. Focusing on one a single number misses the point, and everyone we have spoken with in the Pizza Napoletana community concurs. It’s sort of like saying “mine goes to 11.”

What everyone does agree on is that a high heat, wood-fired oven is the best and only way to bake an authentic pizza, and that the quality of your finished pizza relies on the technique you use when making your dough and dough balls, the quality of the ingredients you use, and how delicately you shape and assemble your pizza – along with how well you manage your oven.

## **13. Pizza Baking**

Your oven is fired, the dome is white, and the cooking floor is clean. You have assembled your first pizza, and you are ready to go. Test to make sure your pizza is not stuck on your peel by moving your peel forward and backward using short jerks - it should slide easily around. If it does stick, lift it up on one side using your fingers, and throw a little flour underneath. Slide

your peel back and forth, and that should loosen it up.

If your pizzas consistently stick to the peel, use more flour underneath your pizza dough before you start decorating. Also, if you have a group of people assembling pizzas, and one sits for a while before you place it in the oven, there is a large chance it will stick.

Next, choose a target roughly centered between the fire and dome wall – at least 6" away from the edge of the fire. The best way to place your pizza is to push your peel toward your spot, then stop it just short that spot, allowing the pizza to slide off the peel. Pull the peel backward as the pizza slides forward.

You will know that your oven is hot enough to bake correctly when the cornicione of the fresh pizza puffs up almost immediately.

After about 60 seconds, slide your turning peel under the pizza and turn it 180 degrees, so that the side that was furthest from the fire is now facing it. The Forno Bravo round turning peel has a hand glide that allows you to rotate the peel under the pizza in order to easily rotate it.

If your pizza is burning on the side facing the fire, you should turn it sooner. After another 45-90 seconds, your pizza should be done. You can also try turning your pizza twice, rotating it in thirds. Experiment, and stick with what works best for you.

Optionally, you can lift your pizza up for the last few seconds with your peel, holding it closer to the dome. The reflecting heat of the dome will quickly finish baking your pizza if the top is not quite done.

If you have a larger oven that can hold four or more pizzas, not all of the pizzas of the pizzas can be placed directly across from the fire. In that case, you should start your pizzas in the zone closest to the fire, then move them to the outer zone to finish baking. You will find a rhythm where you will take one pizza out,



# Residential Assembled Ovens

Primavera, Napolino. Andiamo, Strada

move a pizza from the starting zone to the finishing zone, and place a new pizza in the starting zone. The perfect pizza is bubbling on top with completely melted and browned cheese, and has a brown outer crust, and a dark brown bottom. The crust is crunchy on the outside and soft and delicate on the inside. Everything is steaming hot. Throw on some fresh basil, use a pizza cutting wheel to cut your pizza into six or eight pieces and you have done it.

Don't forget to keep adding wood to your fire to keep the flame active.



# Residential Assembled Ovens

Primavera, Napolino. Andiamo, Strada

## Appendix 1. Cucina Stand Assembly

The Cucina stand is an optional modular metal stand frame for creating a “built-in” look for the Forno Bravo residential ovens. The stand consists of a metal stand frame and hearth tray, along with pre-cut and pre-drilled backer board panels that face the outside and inside of the stand and form the bottom of the hearth tray. The stand is designed to hold a customer-installed concrete hearth and decorative finish, such as stucco, stone or brick.

### Assembly Instructions

1. Bolt the metal frame together and set it in place.
2. Screw the backer panels to the outside of the frame. Do not worry if there are gaps between the panels. The stand will be covered with a decorative finish.
3. Lay the top tray panel into the hearth tray and support it with a customer supplied support built using 2" x 4" (5 cm x 10cm)lumber. The support will hold the tray panel and concrete in place while the wet concrete is curing. Cut the 2" x 4" (5 cm x 10cm) lumber to make a “T” under the panel, where the top of the support touches the bottom of the panel.
4. Place a grid of 1/4" (6.3 mm)rebar running in both directions every 10" (304 cm), in the center of the tray (equal amounts of concrete above and below the rebar grid).
5. Mix and pour standard pre-mix concrete to fill the tray, and leave it to cure for 24 hours.
6. Remove the support.
7. Place the oven on top of the concrete hearth.

For additional information, watch the [installation video](#).

**Do not place an assembled Forno Bravo oven inside the stand tray. The stand is not designed to accurately fit the size of any assembled oven and you will damage the oven enclosure if you try to make it fit. Pour a concrete hearth and place the assembled oven on top of the cured concrete.**



Gas option: a minimum of 19 3/4" w x 19 3/4" h (50.1 cm w x 50.1 cm h) opening is required for air flow to burner assembly.

# Residential Assembled Ovens

Primavera, Napolino. Andiamo, Strada

## Appendix 2: Oven Dimensions

Primavera 60-W-FA.....	21
Primavera 70-W-FA.....	25
Napolino 60-W-FA.....	29
Napolino 70-W-FA.....	33
Andiamo 60-W-FA.....	37
Andiamo 70-W-FA.....	38
Strada 60-W-FA.....	39



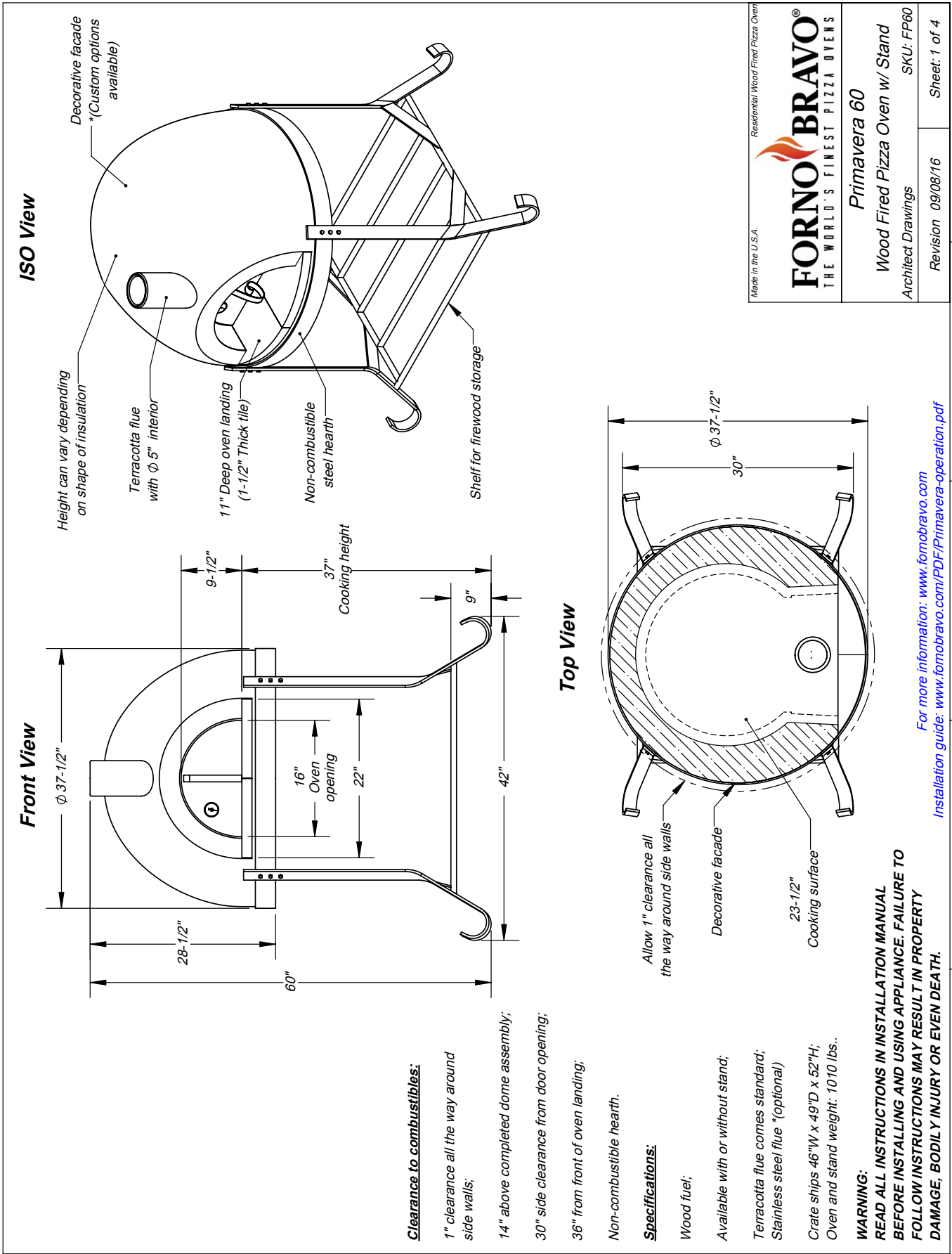

Made in the U.S.A. Residential Wood Fired Pizza Oven

**FORNO BRAVO®**  
 THE WORLD'S FINEST PIZZA OVENS

**Primavera 60**

Wood Fired Pizza Oven w/ Stand

Architect Drawings SKU: FP60

Revision 09/08/16 Sheet: 1 of 4

For more information: [www.fornobravo.com](http://www.fornobravo.com)  
 Installation guide: [www.fornobravo.com/PDF/Primavera-operation.pdf](http://www.fornobravo.com/PDF/Primavera-operation.pdf)

**Front View**

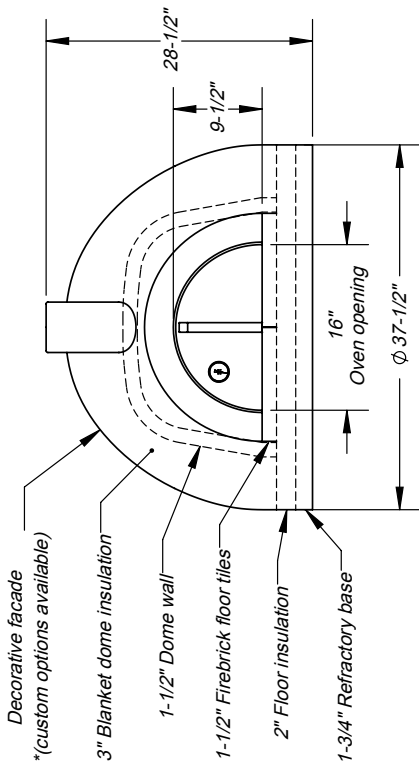

**Side Elevation**

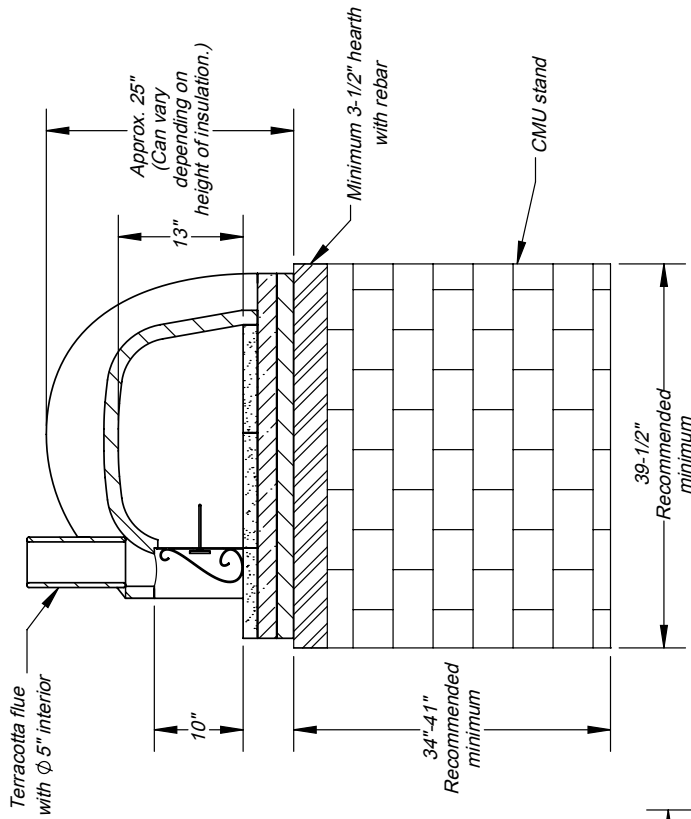

**Top View**

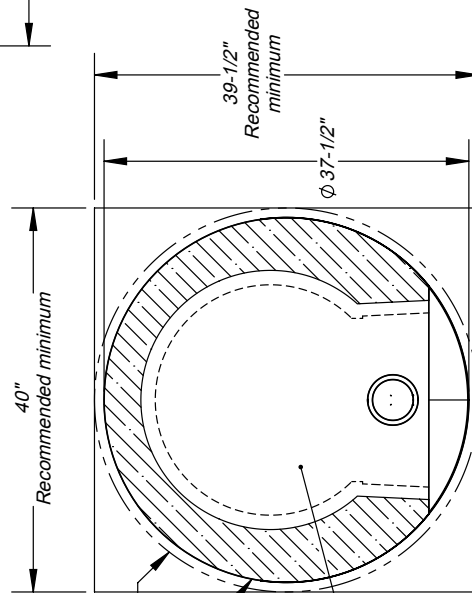

**Clearance to combustibles:**

- 1" clearance all the way around side walls;
- 14" above completed dome assembly;
- 30" side clearance from door opening;
- 36" from front of oven landing;

Allow 1" clearance all the way around side walls

Decorative facade

23-1/2" Cooking surface

**Specifications:**

- Wood fuel;
- Shown without stand
- Terracotta flue comes standard.
- Stainless steel fuel \*(optional)
- Crate ships 46"W x 49"D x 42"H;
- Oven weight: 900 lbs.

**WARNING:**  
**READ ALL INSTRUCTIONS IN INSTALLATION MANUAL BEFORE INSTALLING AND USING APPLIANCE. FAILURE TO FOLLOW INSTRUCTIONS MAY RESULT IN PROPERTY DAMAGE, BODILY INJURY OR EVEN DEATH.**

For more information: [www.fornobravo.com](http://www.fornobravo.com)  
 Installation guide: [www.fornobravo.com/PDF/Primavera-operation.pdf](http://www.fornobravo.com/PDF/Primavera-operation.pdf)

Made in the U.S.A.

Residential Wood Fired Pizza Oven

**Primavera 60 NS**

Wood Fired Pizza Oven w/o Stand

Architect Drawings SKU: FP60-NS

Revision 09/08/16 Sheet: 2 of 4

**ISO View**

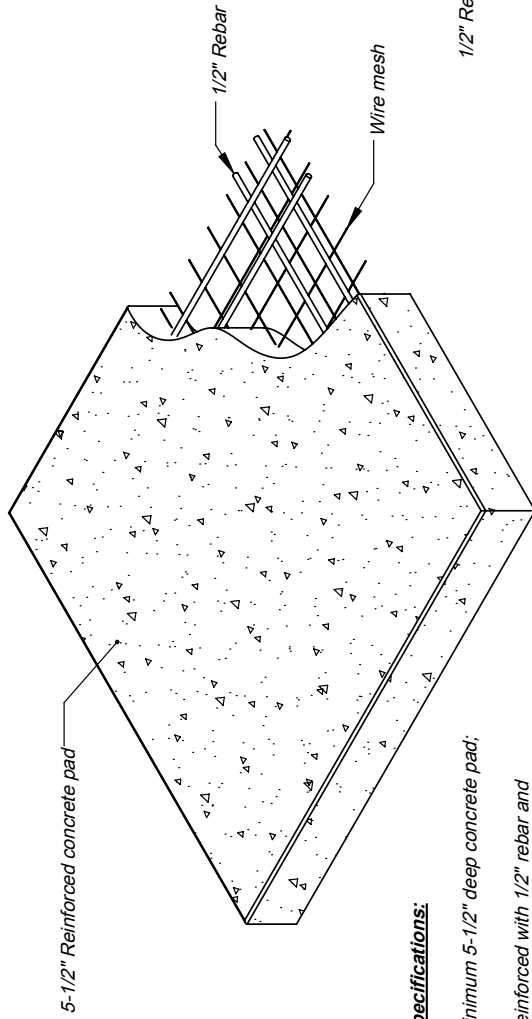

**Specifications:**

Minimum 5-1/2" deep concrete pad;

Reinforced with 1/2" rebar and wire mesh. \* wire mesh is not shown in some views for print clarity;

Cut rebar and wire mesh short to conceal inside concrete pad;

\*CMU stand requires a minimum cement foundation pad of 48"W x 50"L

**Slab dimensions:**

Minimum 8" wider than oven stand and hearth;

Minimum 10" deeper than oven stand and hearth;

Finished slab should be 2" to 3" above ground level;

Refer to local building codes for recommendations regarding soil compaction, frost line and other considerations. Depending on local conditions, you may have to excavate down 18" or more of topsoil to reach stable substrate.

**WARNING:**

READ ALL INSTRUCTIONS IN INSTALLATION MANUAL BEFORE INSTALLING AND USING APPLIANCE. FAILURE TO FOLLOW INSTRUCTIONS MAY RESULT IN PROPERTY DAMAGE, BODILY INJURY OR EVEN DEATH.

**Top View**

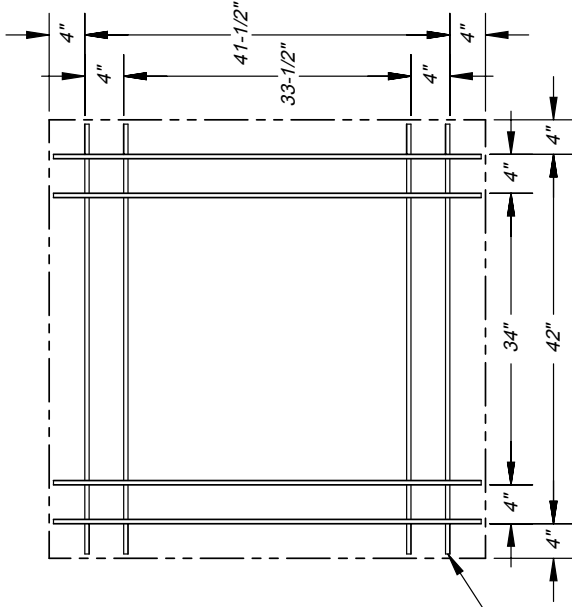

**Side Elevation**

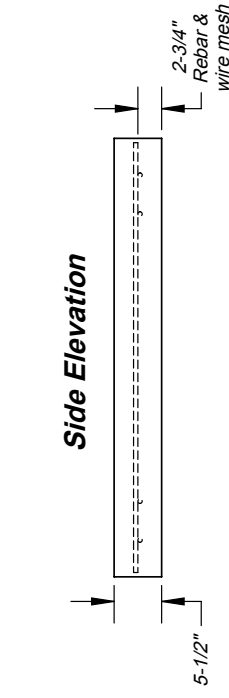

**Primavera 60 oven stand footprint**

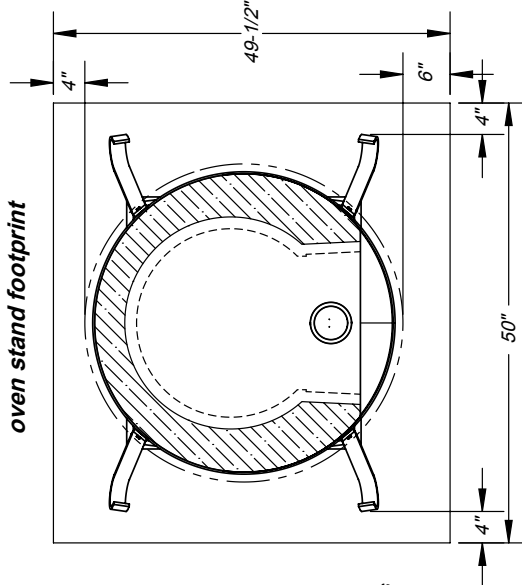

Made in the U.S.A.



Primavera 60

Wood Fired Pizza Oven Pad

Architect Drawings

Revision 09/08/2016

Sheet: 3 of 4

For more information: [www.fornobravo.com](http://www.fornobravo.com)  
Installation guide: [www.fornobravo.com/PDF/Primavera-operation.pdf](http://www.fornobravo.com/PDF/Primavera-operation.pdf)



**ISO View**

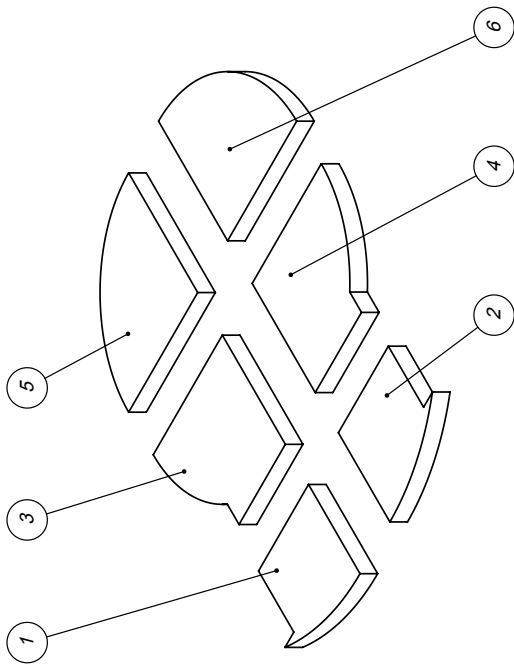

When ordering replacement tiles, reference tile number, pizza oven model and purchase date

**Top View**

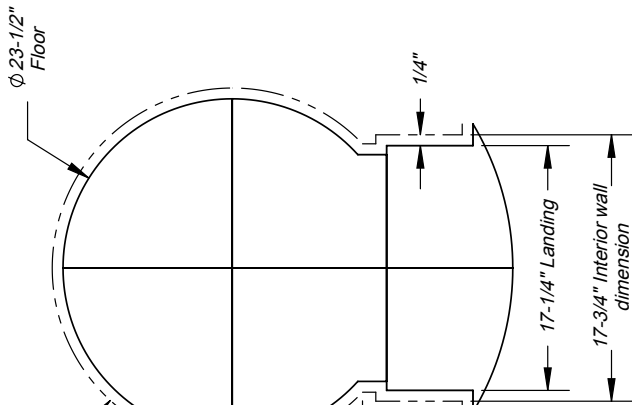

Ø 24" Interior dome dimension

Pizza oven floor designed to allow approximately 1/2" gap between cooking surface and interior dome for thermal expansion and contraction during operation.

Do not fill inside wall with mortar or similar bonding agent. If preferred the space can be filled with sand.

Gaps between the wall and front landing can be filled with mortar or equivalent bonding agent.

**Side Elevation**

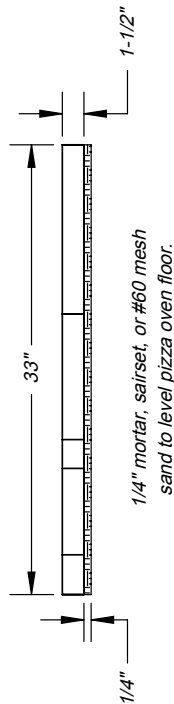

**Specifications:**

Pizza oven floor is NS-4 rated with 1-1/2" thick surface.

Use 1/4" mortar, salsit, or #60 mesh sand to level the floor.

No more than 3/8" filler around landing or door may not fit.

**WARNING:**  
 READ ALL INSTRUCTIONS IN INSTALLATION MANUAL BEFORE INSTALLING AND USING APPLIANCE. FAILURE TO FOLLOW INSTRUCTIONS MAY RESULT IN PROPERTY DAMAGE, BODILY INJURY OR EVEN DEATH.

For more information: [www.fornobravo.com](http://www.fornobravo.com)  
 Installation guide: [www.fornobravo.com/PDF/Primavera-operation.pdf](http://www.fornobravo.com/PDF/Primavera-operation.pdf)

Made in the U.S.A.

Residential Wood Fired Pizza Oven



Primavera 60

Pizza Oven Floor Tile Layout

Architect Drawings

Revision 09/08/16

Sheet: 4 of 4

1 2 3 4 5



**Front View**

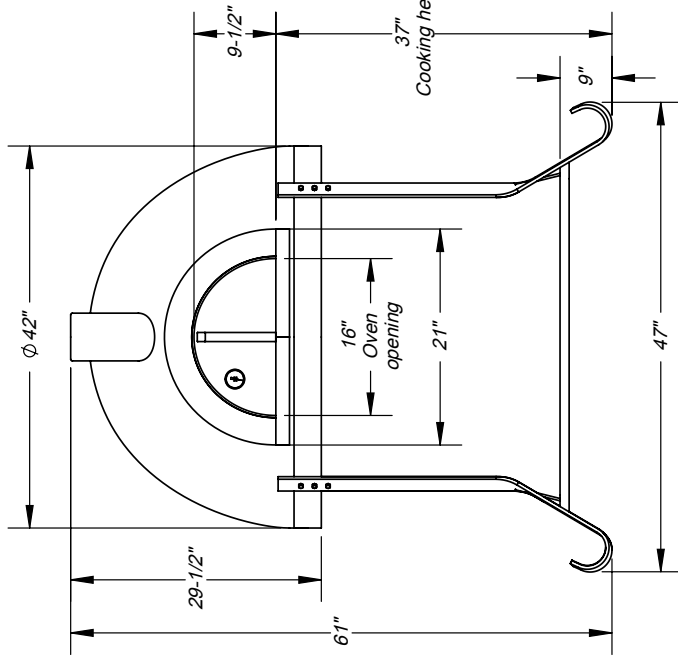

**ISO View**

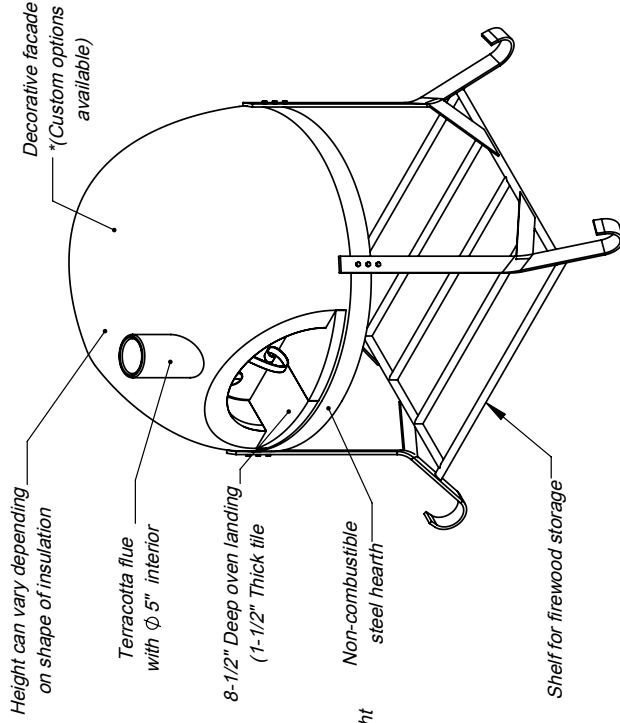

**Clearance to combustibles:**

- 1" clearance all the way around side walls;
- 14" above completed dome assembly;
- 30" side clearance from door opening;
- 36" from front of oven landing;

Non-combustible hearth.

**Specifications:**

- Wood fuel;
- Available with or without stand;
- Terracotta flue comes standard;
- Stainless steel flue \*(optional)
- Crate ships 49"W x 50"D x 52"H;
- Oven and stand weight: 1050 lbs..

**WARNING:**  
**READ ALL INSTRUCTIONS IN INSTALLATION MANUAL BEFORE INSTALLING AND USING APPLIANCE. FAILURE TO FOLLOW INSTRUCTIONS MAY RESULT IN PROPERTY DAMAGE, BODILY INJURY OR EVEN DEATH.**

**Top View**

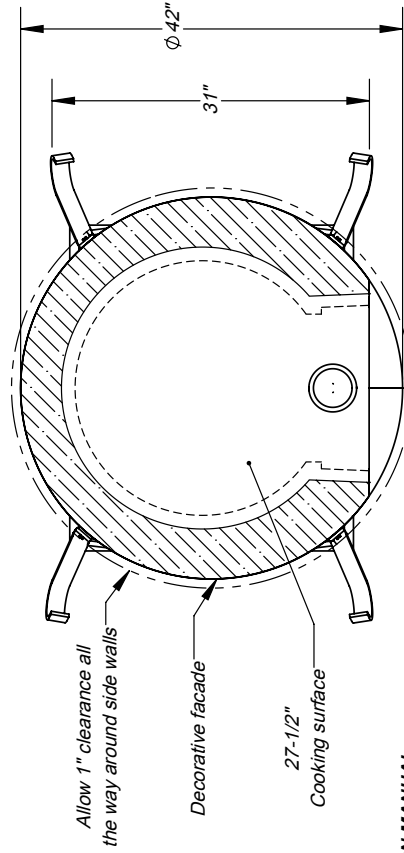

Allow 1" clearance all the way around side walls

Decorative facade

27-1/2" Cooking surface

Made in the U.S.A.  
 Residential Wood Fired Pizza Oven  
**FORNO BRAVO®**  
 THE WORLD'S FINEST PIZZA OVENS  
**Primavera 70**  
 Wood Fired Pizza Oven w/ Stand  
 Architect Drawings SKU: FP70  
 Revision 09/08/16 Sheet: 1 of 4

For more information: [www.fornobravo.com](http://www.fornobravo.com)  
 Installation guide: [www.fornobravo.com/PDF/Primavera-operation.pdf](http://www.fornobravo.com/PDF/Primavera-operation.pdf)

### Front View

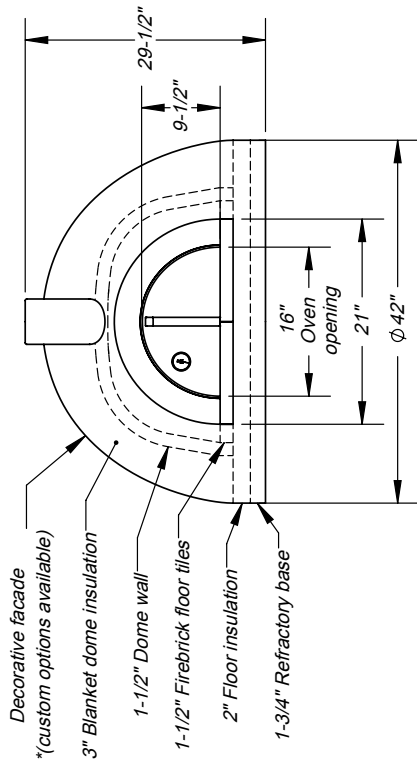

### Side Elevation

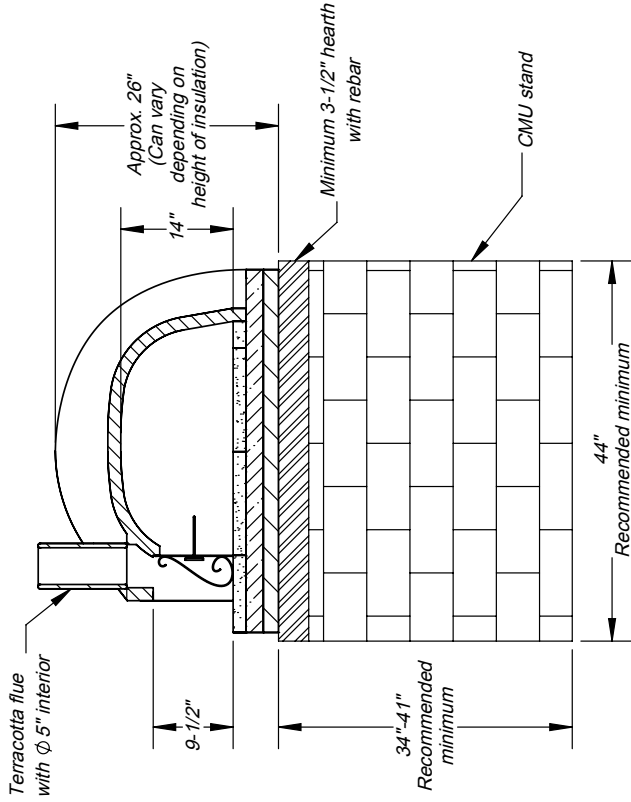

### Top View

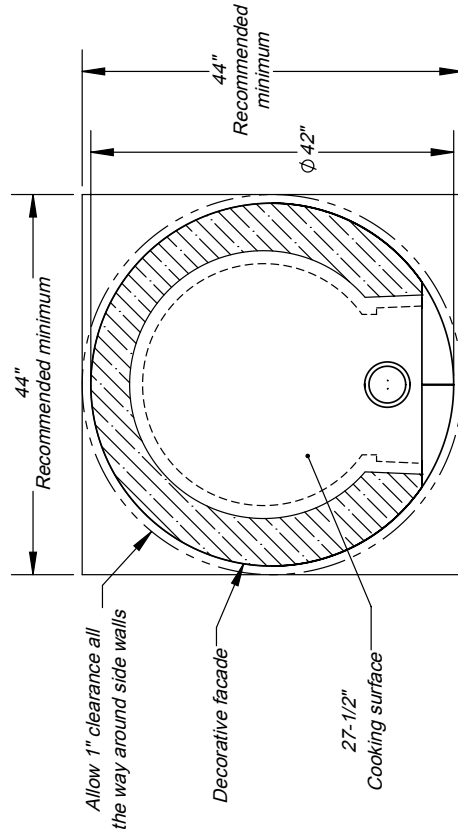

#### Clearance to combustibles:

- 1" clearance all the way around side walls;
- 14" above completed dome assembly;
- 30" side clearance from door opening;
- 36" from front of oven landing;

Non-combustible hearth.

#### Specifications:

- Wood fuel;
- Shown without stand
- Terracotta flue comes standard.
- Stainless steel flue \*(optional)
- Crate ships 49"W x 50"D x 42"H;
- Oven weight: 1230 lbs..

**WARNING:**  
**READ ALL INSTRUCTIONS IN INSTALLATION MANUAL BEFORE INSTALLING AND USING APPLIANCE. FAILURE TO FOLLOW INSTRUCTIONS MAY RESULT IN PROPERTY DAMAGE, BODILY INJURY OR EVEN DEATH.**

Made in the U.S.A.

**FORNO BRAVO®**  
 THE WORLD'S FINEST PIZZA OVENS

Residential Wood Fired Pizza Oven

**Primavera 70 NS**

Wood Fired Pizza Oven w/o Stand

Architect Drawings SKU: FP70-NS

Revision 09/08/16 Sheet: 2 of 4

For more information: [www.fornobravo.com](http://www.fornobravo.com)  
 Installation guide: [www.fornobravo.com/PDF/Primavera-operation.pdf](http://www.fornobravo.com/PDF/Primavera-operation.pdf)

**ISO View**

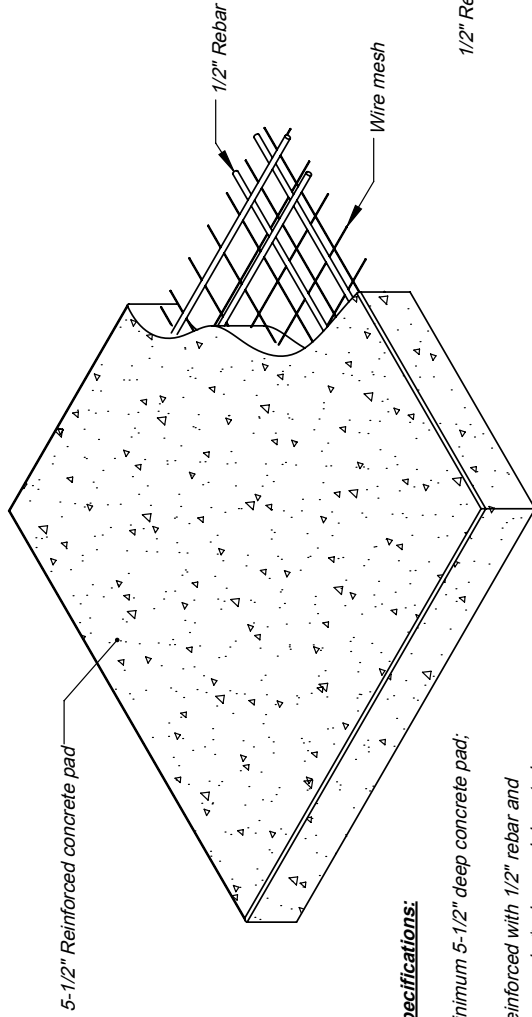

**Top View**

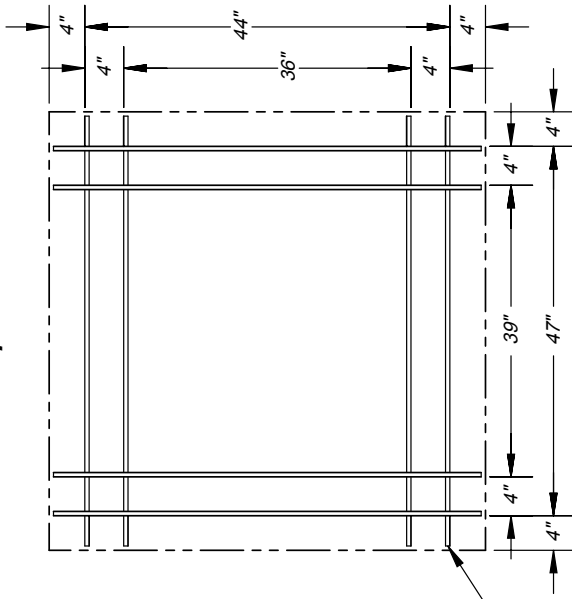

**Primavera 70 oven stand footprint**

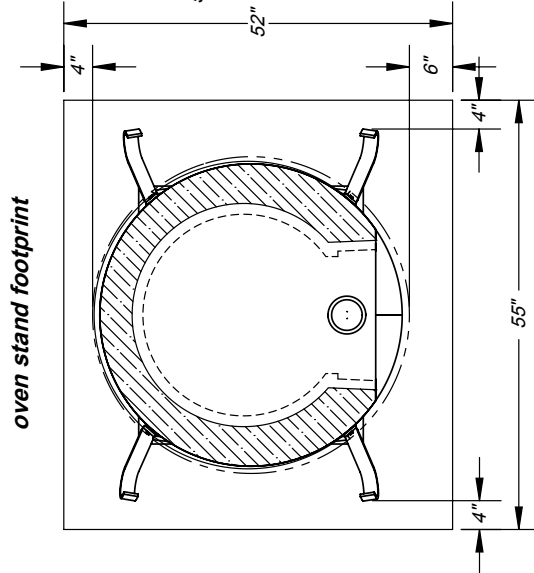

**Side Elevation**

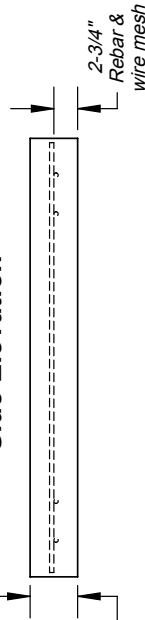

5-1/2" Reinforced concrete pad

1/2" Rebar

Wire mesh

Minimum 5-1/2" deep concrete pad;

Reinforced with 1/2" rebar and wire mesh. \* wire mesh is not shown in some views for print clarity;

Cut rebar and wire mesh short to conceal inside concrete pad;

\*CMU stand requires a minimum cement foundation pad of 52"W x 54"L.

**Slab dimensions:**

Minimum 8" wider than oven stand and hearth;

Minimum 10" deeper than oven stand and hearth;

Finished slab should be 2" to 3" above ground level;

Refer to local building codes for recommendations regarding soil compaction, frost line and other considerations. Depending on local conditions, you may have to excavate down 18" or more of topsoil to reach stable substrate.

**WARNING:**

READ ALL INSTRUCTIONS IN INSTALLATION MANUAL BEFORE INSTALLING AND USING APPLIANCE. FAILURE TO FOLLOW INSTRUCTIONS MAY RESULT IN PROPERTY DAMAGE, BODILY INJURY OR EVEN DEATH.

Made in the U.S.A. Residential Wood Fired Pizza Oven

**FORNO BRAVO®**  
THE WORLD'S FINEST PIZZA OVENS

Primavera 70

Wood Fired Pizza Oven Pad

Architect Drawings

Revision 09/08/2016

Sheet: 3 of 4

For more information: [www.fornobravo.com](http://www.fornobravo.com)  
Installation guide: [www.fornobravo.com/PDF/Primavera-operation.pdf](http://www.fornobravo.com/PDF/Primavera-operation.pdf)

**ISO View**

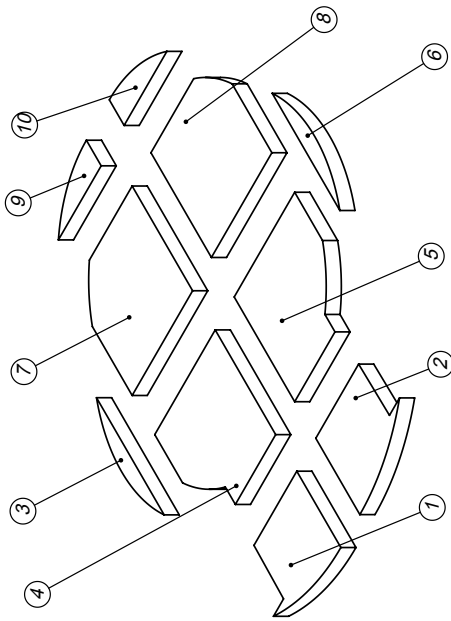

When ordering replacement tiles, reference tile number, pizza oven model and purchase date.

**Top View**

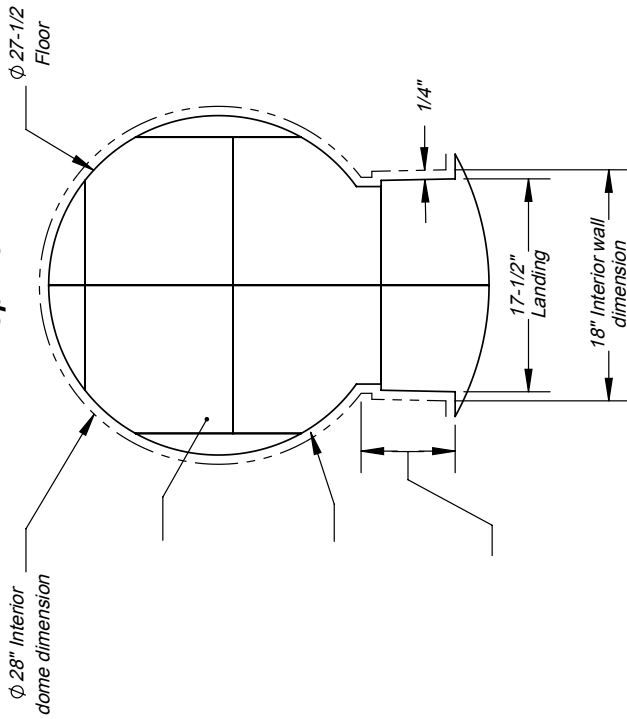

**Side Elevation**

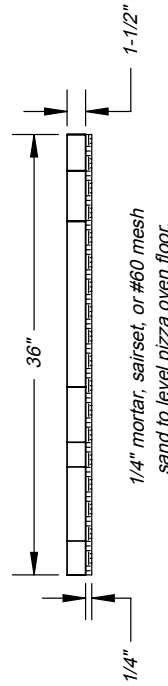

**Specifications:**

Pizza oven floor is NSF-4 rated with 1-1/2" thick surface.

Use 1/4" mortar, sairset, or #60 mesh sand to level the floor.

No more than 3/8" filler around landing or door may not fit.

**WARNING:**

**READ ALL INSTRUCTIONS IN INSTALLATION MANUAL BEFORE INSTALLING AND USING APPLIANCE. FAILURE TO FOLLOW INSTRUCTIONS MAY RESULT IN PROPERTY DAMAGE, BODILY INJURY OR EVEN DEATH.**

Made in the U.S.A.

Residential Wood Fired Pizza Oven



**Primavera 70**

Pizza Oven Floor Tile Layout

Architect Drawings

Revision 09/08/16 Sheet: 4 of 4

For more information: [www.fornobravo.com](http://www.fornobravo.com)  
 Installation guide: [www.fornobravo.com/PDF/Primavera-operation.pdf](http://www.fornobravo.com/PDF/Primavera-operation.pdf)

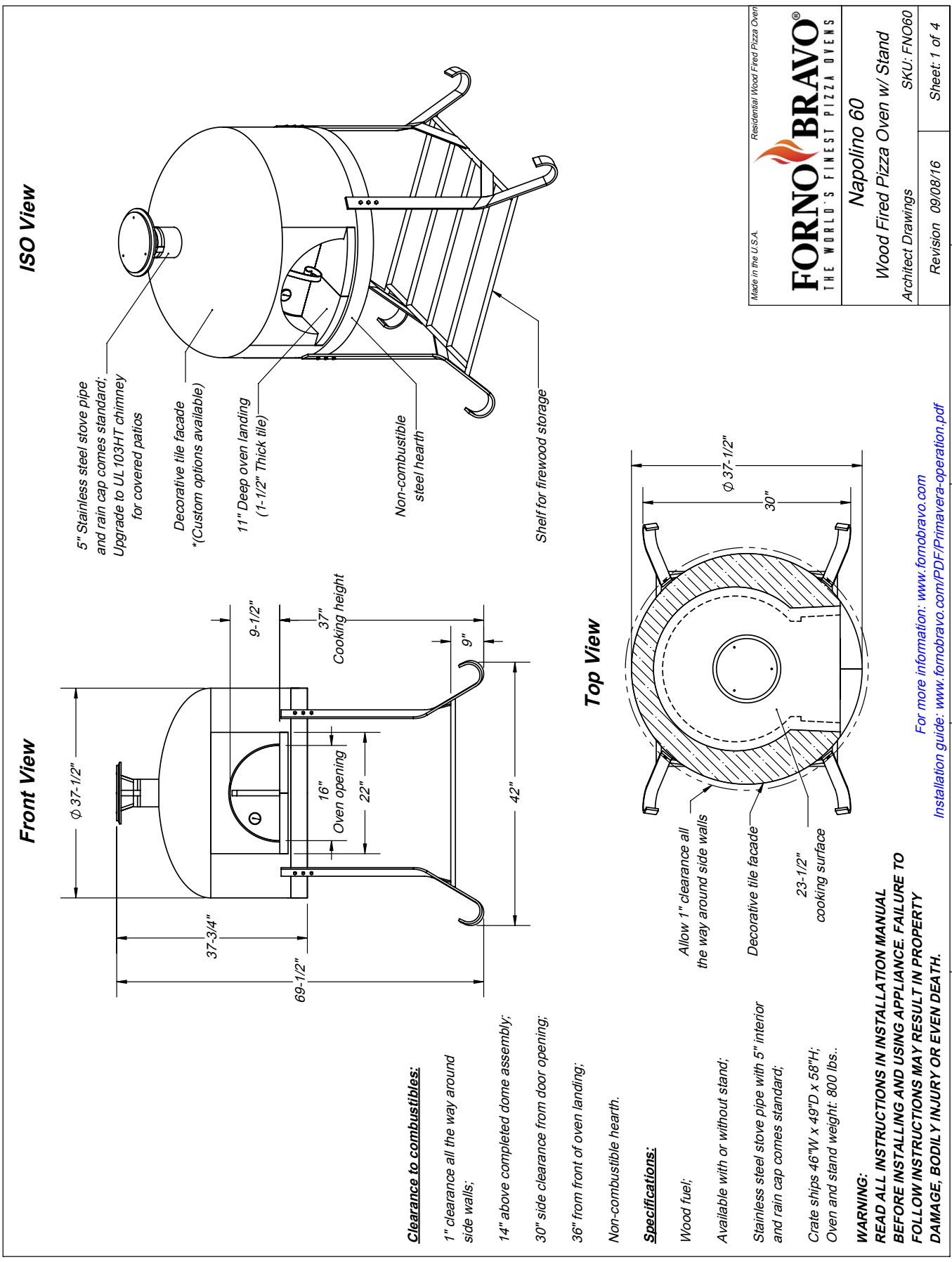

**Clearance to combustibles:**

- 1" clearance all the way around side walls;
- 14" above completed dome assembly;
- 30" side clearance from door opening;
- 36" from front of oven landing;

Non-combustible hearth.

**Specifications:**

- Wood fuel;
- Available with or without stand;
- Stainless steel stove pipe with 5" interior and rain cap comes standard;
- Crate ships 46"W x 49"D x 58"H;
- Oven and stand weight: 800 lbs..

**WARNING:**  
**READ ALL INSTRUCTIONS IN INSTALLATION MANUAL BEFORE INSTALLING AND USING APPLIANCE. FAILURE TO FOLLOW INSTRUCTIONS MAY RESULT IN PROPERTY DAMAGE, BODILY INJURY OR EVEN DEATH.**

Made in the U.S.A. Residential Wood Fired Pizza Oven

**FORNO BRAVO®**  
 THE WORLD'S FINEST PIZZA OVENS

**Napolino 60**

Wood Fired Pizza Oven w/ Stand  
 Architect Drawings SKU: FNO60

Revision 09/08/16 Sheet: 1 of 4

For more information: [www.fornobravo.com](http://www.fornobravo.com)  
 Installation guide: [www.fornobravo.com/PDF/Primavera-operation.pdf](http://www.fornobravo.com/PDF/Primavera-operation.pdf)

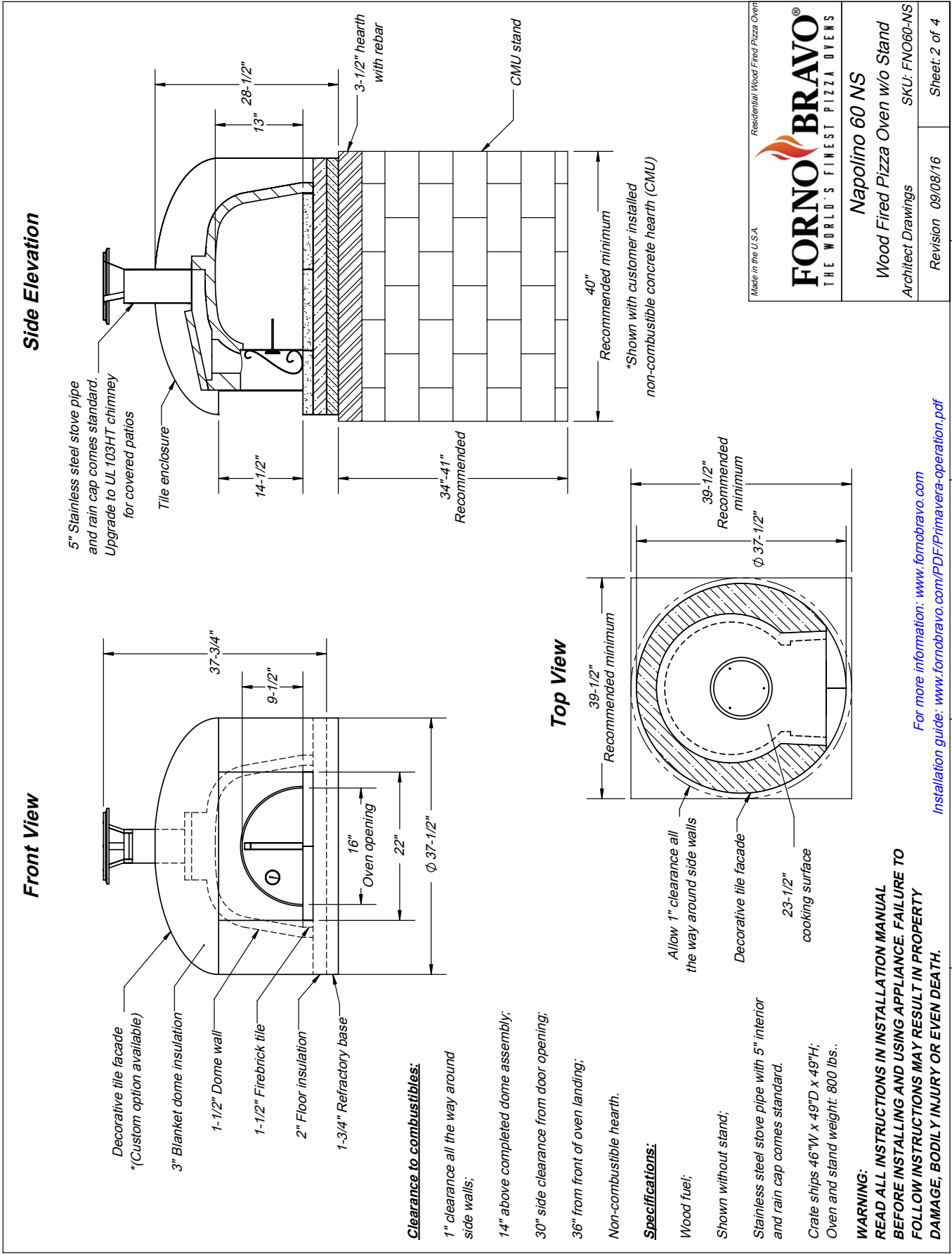

Made in the U.S.A.

**FORNO BRAVO®**  
THE WORLD'S FINEST PIZZA OVENS

Residential Wood Fired Pizza Oven

**Napolino 60 NS**

Wood Fired Pizza Oven w/o Stand

Architect Drawings SKU: FNO60-NS

Revision 09/08/16 Sheet: 2 of 4

**Front View**

**Side Elevation**

**Top View**

**Clearance to combustibles:**

- 1" clearance all the way around side walls;
- 14" above completed dome assembly;
- 30" side clearance from door opening;
- 36" from front of oven landing;
- Non-combustible hearth.

**Specifications:**

- Wood fuel;
- Shown without stand;
- Stainless steel stove pipe with 5" interior and rain cap comes standard.
- Crate ships 46"W x 49"D x 49"H;
- Oven and stand weight: 800 lbs..

**WARNING:**  
READ ALL INSTRUCTIONS IN INSTALLATION MANUAL BEFORE INSTALLING AND USING APPLIANCE. FAILURE TO FOLLOW INSTRUCTIONS MAY RESULT IN PROPERTY DAMAGE, BODILY INJURY OR EVEN DEATH.

For more information: [www.fornobravo.com](http://www.fornobravo.com)  
Installation guide: [www.fornobravo.com/PDF/Primavera-operation.pdf](http://www.fornobravo.com/PDF/Primavera-operation.pdf)

**ISO View**

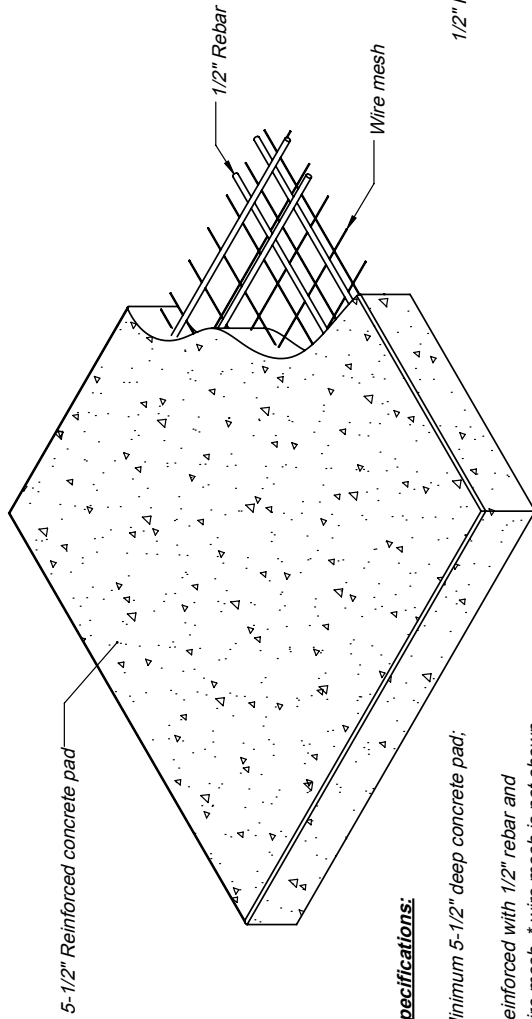

**Top View**

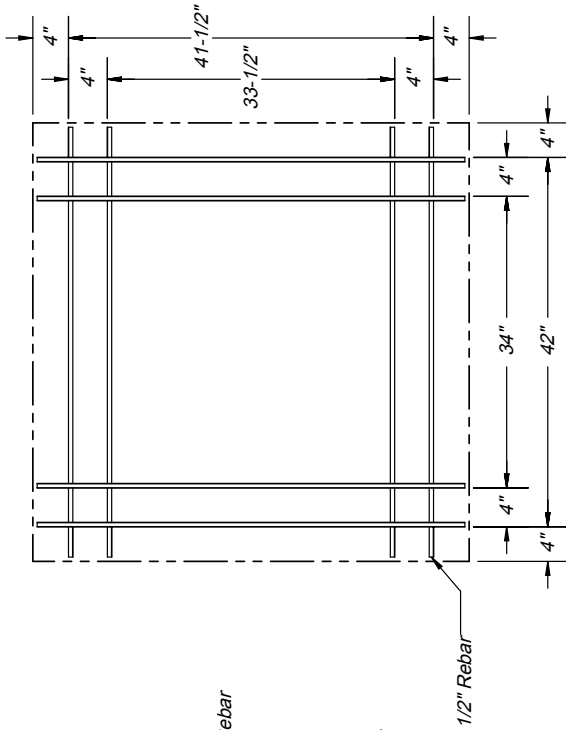

**Napolino 60  
oven stand footprint**

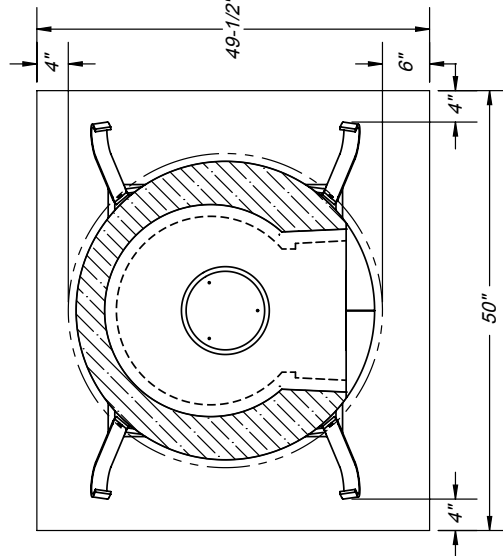

**Side Elevation**

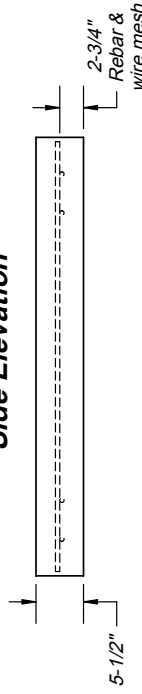

5-1/2" Reinforced concrete pad

**Specifications:**

Minimum 5-1/2" deep concrete pad;

Reinforced with 1/2" rebar and wire mesh. \* wire mesh is not shown in some views for print clarity;

Cut rebar and wire mesh short to conceal inside concrete pad;

\*CMU stand requires a minimum cement foundation pad of 48"W x 50"L

**Slab dimensions:**

Minimum 8" wider than oven stand and hearth;

Minimum 10" deeper than oven stand and hearth;

Finished slab should be 2" to 3" above ground level;

Refer to local building codes for recommendations regarding soil compaction, frost line and other considerations. Depending on local conditions, you may have to excavate down 18" or more of topsoil to reach stable substrate.

**WARNING:**  
READ ALL INSTRUCTIONS IN INSTALLATION MANUAL BEFORE INSTALLING AND USING APPLIANCE. FAILURE TO FOLLOW INSTRUCTIONS MAY RESULT IN PROPERTY DAMAGE, BODILY INJURY OR EVEN DEATH.

Made in the U.S.A.

Residential Wood Fired Pizza Oven

**Napolino 60**  
Wood Fired Pizza Oven Pad  
Architect Drawings

Revision 09/08/16 Sheet: 3 of 4

For more information: [www.fornobravo.com](http://www.fornobravo.com)  
Installation guide: [www.fornobravo.com/PDF/Primavera-operation.pdf](http://www.fornobravo.com/PDF/Primavera-operation.pdf)

### ISO View

When ordering replacement tiles, reference tile number, oven model and purchase date.

### Top View

Pizza oven floor designed to allow approximately 1/2" gap between cooking surface and interior dome for thermal expansion and contraction during operation.

Do not fill inside wall with mortar or similar bonding agent. If preferred the space can be filled with sand.

Gaps between the wall and front landing can be filled with mortar or equivalent bonding agent.

### Side Elevation

1/4" mortar, sairsset, or #60 mesh sand to level floor.

### Specifications:

Pizza oven floor is NSF-4 rated with 1-1/2" thick surface.

Use 1/4" mortar, sairsset, or #60 mesh sand to level the pizza oven floor.

No more than 3/8" filler around landing or door may not fit.

**WARNING:**  
**READ ALL INSTRUCTIONS IN INSTALLATION MANUAL BEFORE INSTALLING AND USING APPLIANCE. FAILURE TO FOLLOW INSTRUCTIONS MAY RESULT IN PROPERTY DAMAGE, BODILY INJURY OR EVEN DEATH.**

For more information: [www.fornobravo.com](http://www.fornobravo.com)  
 Installation guide: [www.fornobravo.com/PDF/Primavera-operation.pdf](http://www.fornobravo.com/PDF/Primavera-operation.pdf)

Made in the U.S.A. <b>FORNO BRAVO</b> <sup>®</sup> THE WORLD'S FINEST PIZZA OVENS	Residential Wood Fired Pizza Oven	<b>Napolino 60</b>	Pizza Oven Floor Tile Layout Architect Drawings	Revision 09/08/16 Sheet: 4 of 4
---	-----------------------------------	--------------------	--	------------------------------------



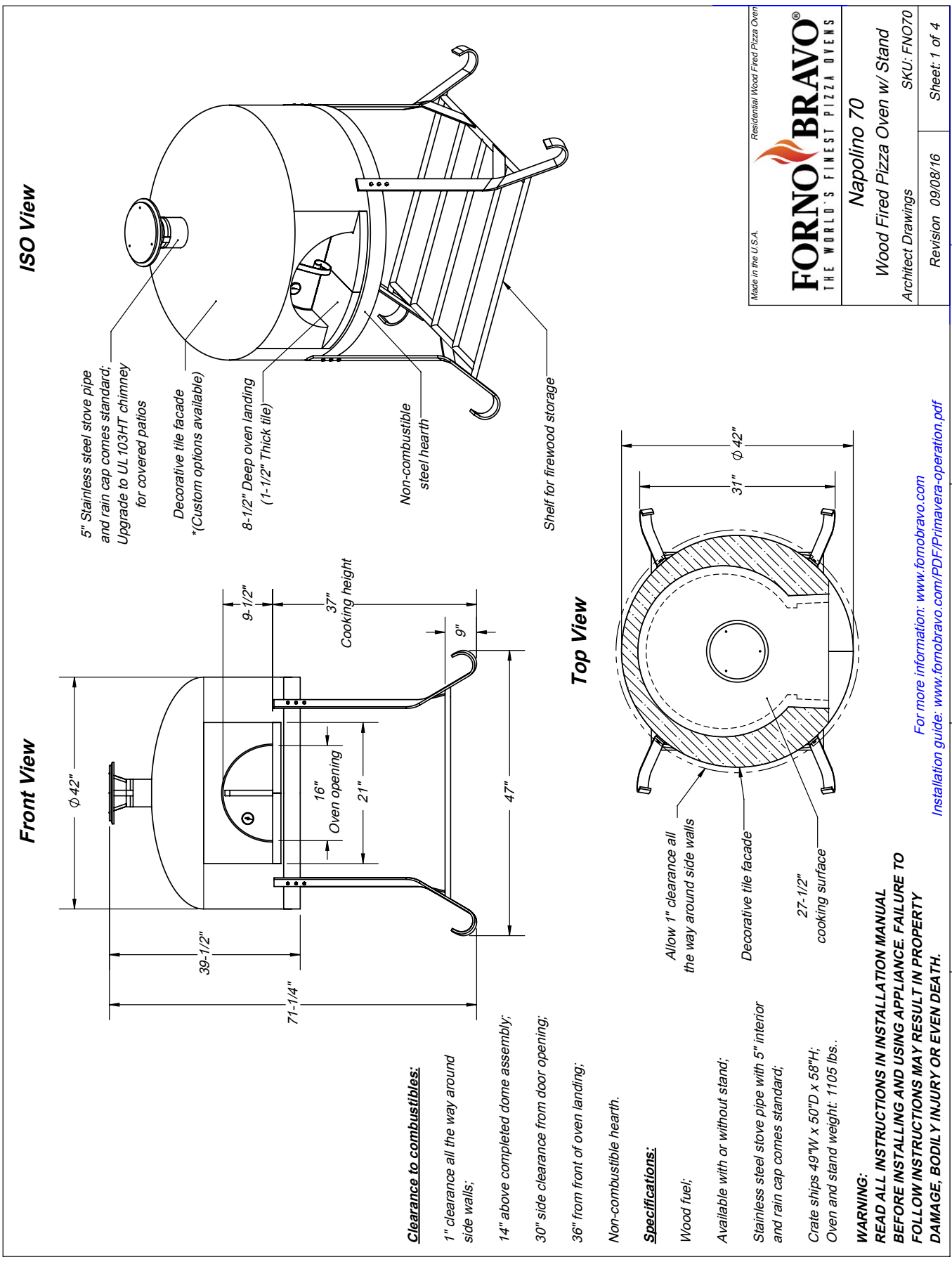

**Clearance to combustibles:**

- 1" clearance all the way around side walls;
- 14" above completed dome assembly;
- 30" side clearance from door opening;
- 36" from front of oven landing;
- 36" non-combustible hearth.

**Specifications:**

- Wood fuel;
- Available with or without stand;
- Stainless steel stove pipe with 5" interior and rain cap comes standard;
- Crate ships 49"W x 50"D x 58"H;
- Oven and stand weight: 1105 lbs..

**WARNING:**  
**READ ALL INSTRUCTIONS IN INSTALLATION MANUAL BEFORE INSTALLING AND USING APPLIANCE. FAILURE TO FOLLOW INSTRUCTIONS MAY RESULT IN PROPERTY DAMAGE, BODILY INJURY OR EVEN DEATH.**

Made in the U.S.A. Residential Wood Fired Pizza Oven

**FORNO BRAVO®**  
 THE WORLD'S FINEST PIZZA OVENS

**Napolino 70**

Wood Fired Pizza Oven w/ Stand  
 Architect Drawings SKU: FNO70

Revision 09/08/16 Sheet: 1 of 4

For more information: [www.fornobravo.com](http://www.fornobravo.com)  
 Installation guide: [www.fornobravo.com/PDF/Primavera-operation.pdf](http://www.fornobravo.com/PDF/Primavera-operation.pdf)

### Front View

### Side Elevation

### Top View

**Clearance to combustibles:**

- 1" clearance all the way around side walls;
- 14" above completed dome assembly;
- 30" side clearance from door opening;
- 36" from front of oven landing;

Non-combustible hearth.

**Specifications:**

- Wood fuel;
- Shown without stand;
- Stainless steel stove pipe with 5" interior and rain cap comes standard.
- Crate ships 49"W x 50"D x 49"H;
- Oven and stand weight: 1320 lbs..

**WARNING:**  
**READ ALL INSTRUCTIONS IN INSTALLATION MANUAL BEFORE INSTALLING AND USING APPLIANCE. FAILURE TO FOLLOW INSTRUCTIONS MAY RESULT IN PROPERTY DAMAGE, BODILY INJURY OR EVEN DEATH.**

**Installation guide:** [www.fornobravo.com/PDF/Primavera-operation.pdf](http://www.fornobravo.com/PDF/Primavera-operation.pdf)

**For more information:** [www.fornobravo.com](http://www.fornobravo.com)

Made in the U.S.A.

**FORNO BRAVO®**  
THE WORLD'S FINEST PIZZA OVENS

---

**Napolino 70 NS**

Wood Fired Pizza Oven w/o Stand

Architect Drawings    SKU: GNO70-NS

---

Revision 09/08/16    Sheet: 2 of 4

1
2
3
4
5

**ISO View**

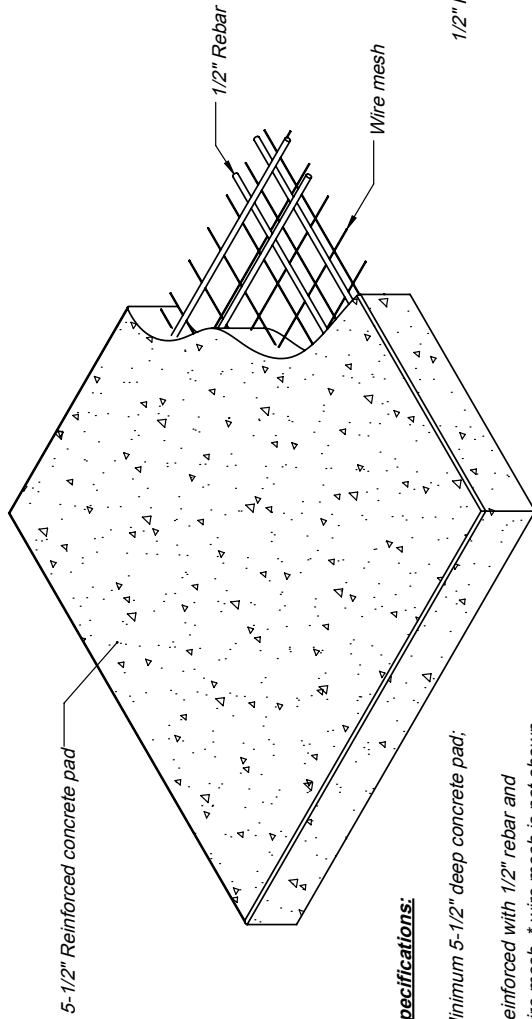

5-1/2" Reinforced concrete pad

**Specifications:**

Minimum 5-1/2" deep concrete pad;

Reinforced with 1/2" rebar and wire mesh. \* wire mesh is not shown in some views for print clarity;

Cut rebar and wire mesh short to conceal inside concrete pad;

\*CMU stand requires a minimum cement foundation pad of 52"W x 54"L

**Slab dimensions:**

Minimum 8" wider than oven stand and hearth;

Minimum 10" deeper than oven stand and hearth;

Finished slab should be 2" to 3" above ground level;

Refer to local building codes for recommendations regarding soil compaction, frost line and other considerations. Depending on local conditions, you may have to excavate down 18" or more of topsoil to reach stable substrate.

**WARNING:**  
 READ ALL INSTRUCTIONS IN INSTALLATION MANUAL BEFORE INSTALLING AND USING APPLIANCE. FAILURE TO FOLLOW INSTRUCTIONS MAY RESULT IN PROPERTY DAMAGE, BODILY INJURY OR EVEN DEATH.

**Top View**

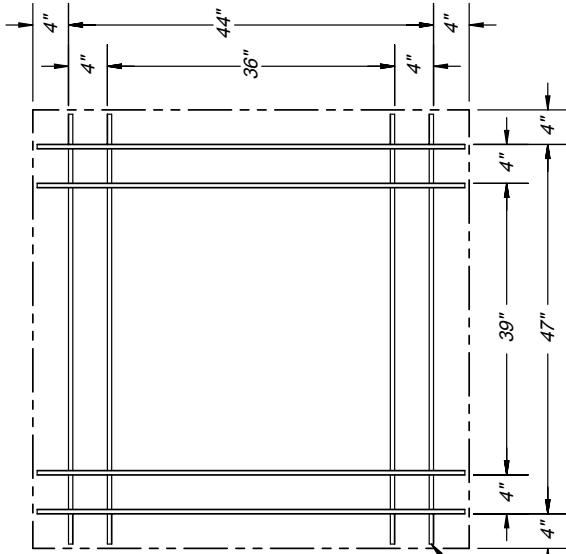

**Side Elevation**

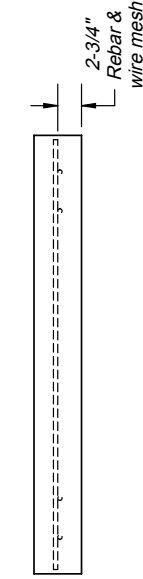

**Napolino 70 oven stand footprint**

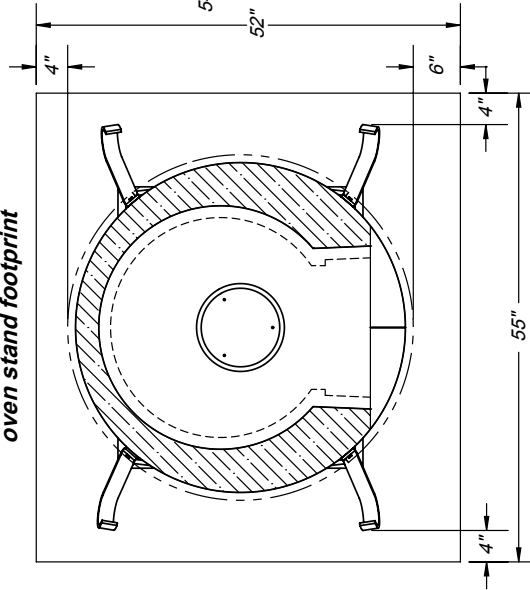

Made in the U.S.A.

**FORNO BRAVO®**  
 THE WORLD'S FINEST PIZZA OVENS

Residential Wood Fired Pizza Oven

---

**Napolino 70**  
 Wood Fired Pizza Oven Pad  
 Architect Drawings

---

Revision 09/08/16 Sheet: 3 of 4

For more information: [www.fornobravo.com](http://www.fornobravo.com)  
 Installation guide: [www.fornobravo.com/PDF/Primavera-operation.pdf](http://www.fornobravo.com/PDF/Primavera-operation.pdf)

### ISO View

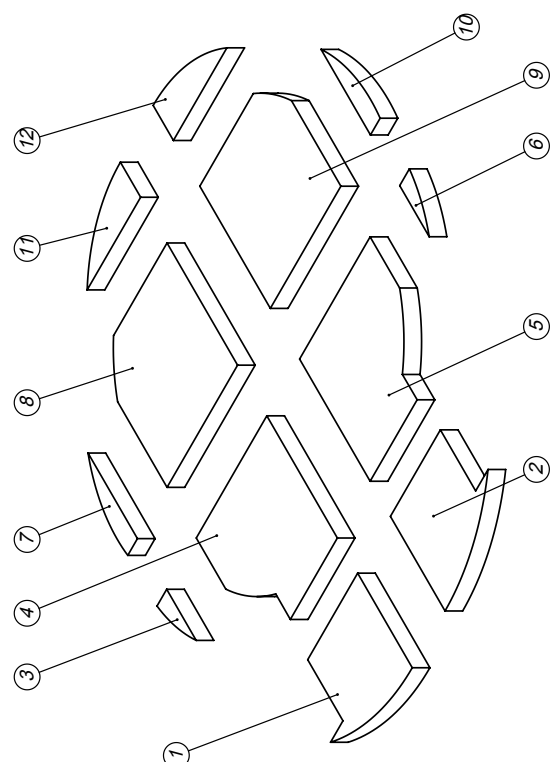

When ordering replacement tiles, reference tile number, pizza oven model and purchase date.

### Top View

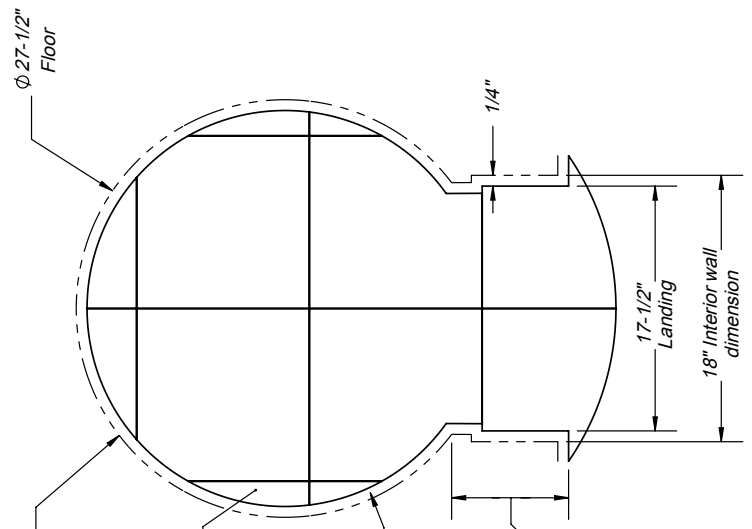

$\phi$  28" Interior dome dimension

$\phi$  27-1/2" Floor

17-1/2" Landing

18" Interior wall dimension

1/4"

Pizza oven floor designed to allow approximately 1/2" gap between cooking surface and interior dome for thermal expansion and contraction during operation.

Do not fill inside wall with mortar or similar bonding agent. If preferred the space can be filled with sand.

Gaps between the wall and front landing can be filled with mortar or equivalent bonding agent.

### Side Elevation

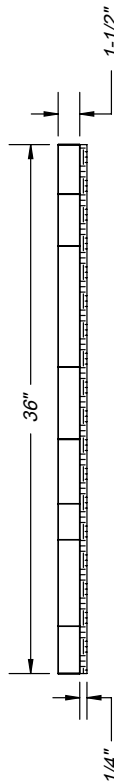

36"

1-1/2"

1/4" mortar, salsiset, or #60 mesh sand to level pizza oven floor.

### Specifications:

Pizza oven floor is NSF-4 rated with 1-1/2" thick surface.

Use 1/4" mortar, salsiset, or #60 mesh sand to level the pizza oven floor.

No more than 3/8" filler around landing or door may not fit.

**WARNING: READ ALL INSTRUCTIONS IN INSTALLATION MANUAL BEFORE INSTALLING AND USING APPLIANCE. FAILURE TO FOLLOW INSTRUCTIONS MAY RESULT IN PROPERTY DAMAGE, BODILY INJURY OR EVEN DEATH.**

For more information: [www.fornobravo.com](http://www.fornobravo.com)

Installation guide: [www.fornobravo.com/PDF/Primavera-operation.pdf](http://www.fornobravo.com/PDF/Primavera-operation.pdf)

Made in the U.S.A.

**FORNO BRAVO**  
 THE WORLD'S FINEST PIZZA OVENS

Residential Wood Fired Pizza Oven

**Napolino 70**

Pizza Oven Floor Tile Layout

Architect Drawings

Revision 09/08/16

Sheet: 4 of 4

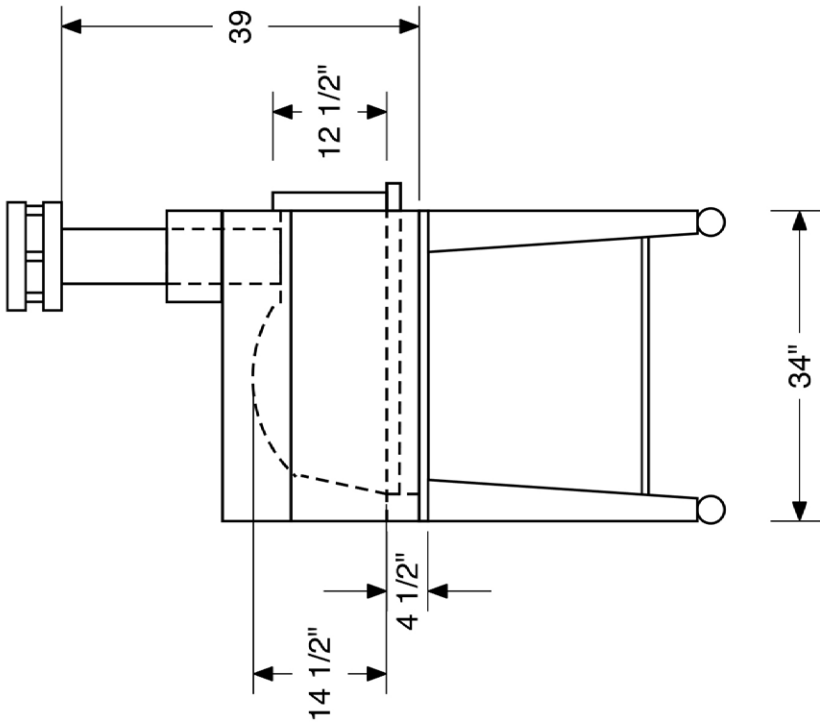
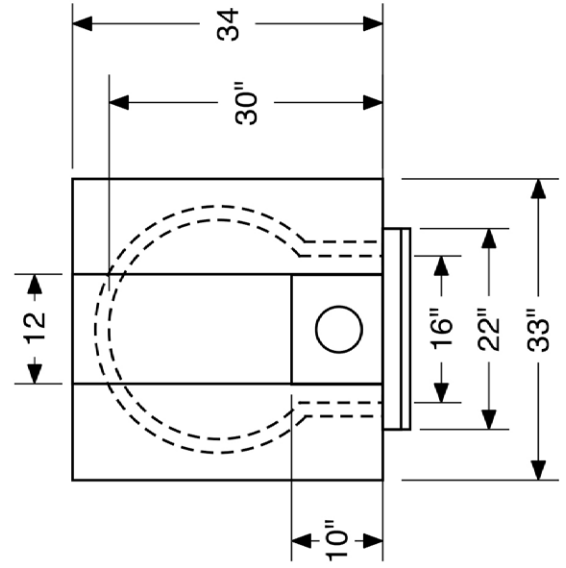
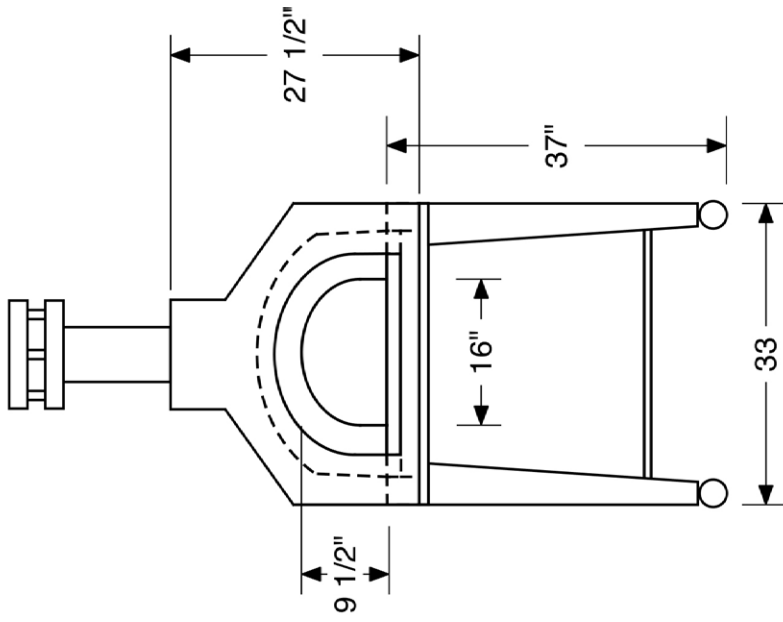

# Andiamo60

v1.2  
12/11  
© Forno Bravo 2011

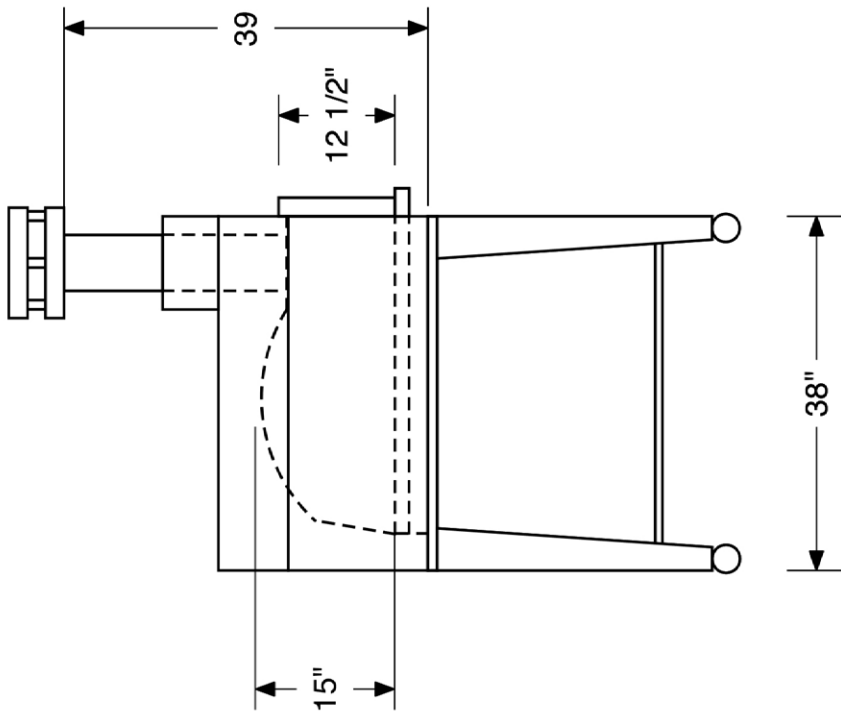
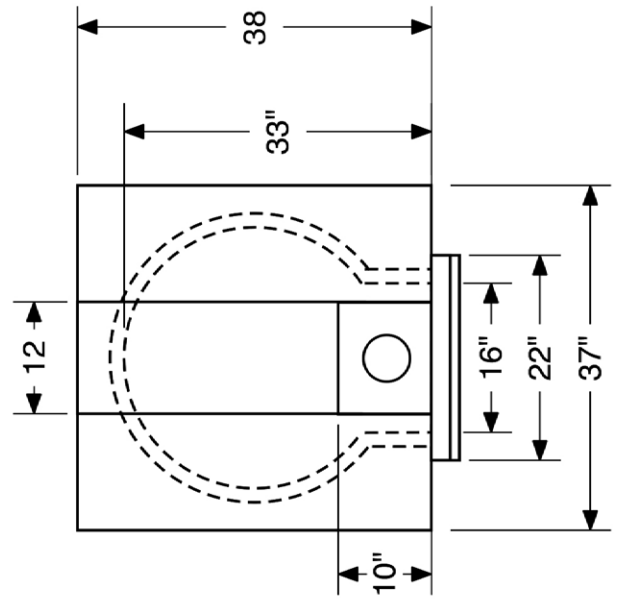
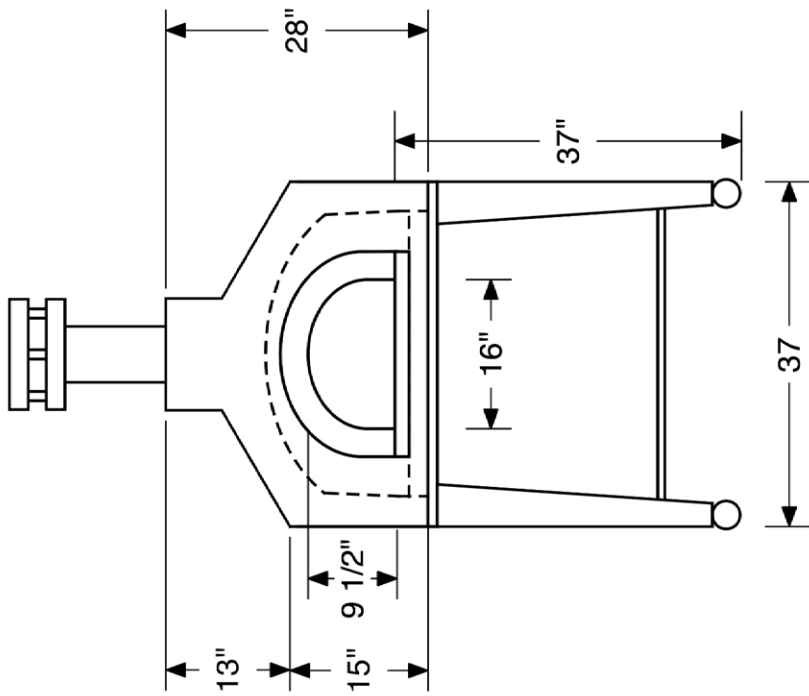

# Andiamo70

v1.0  
12/11  
© Forno Bravo 2011

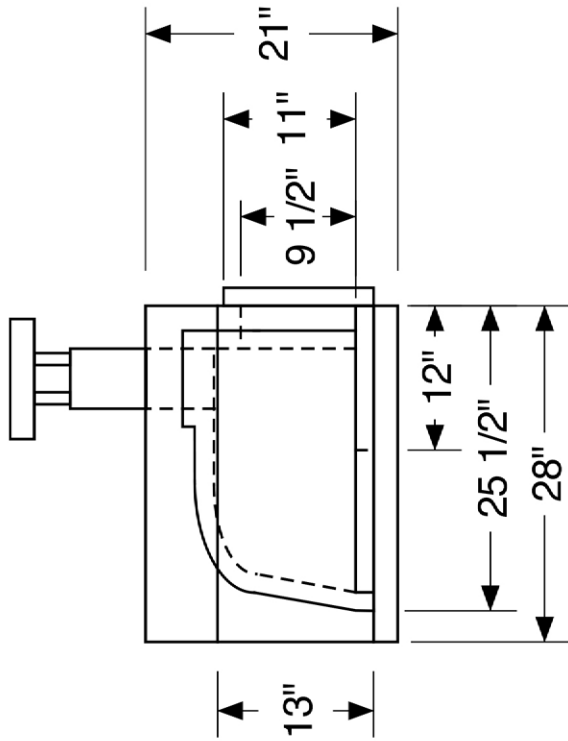
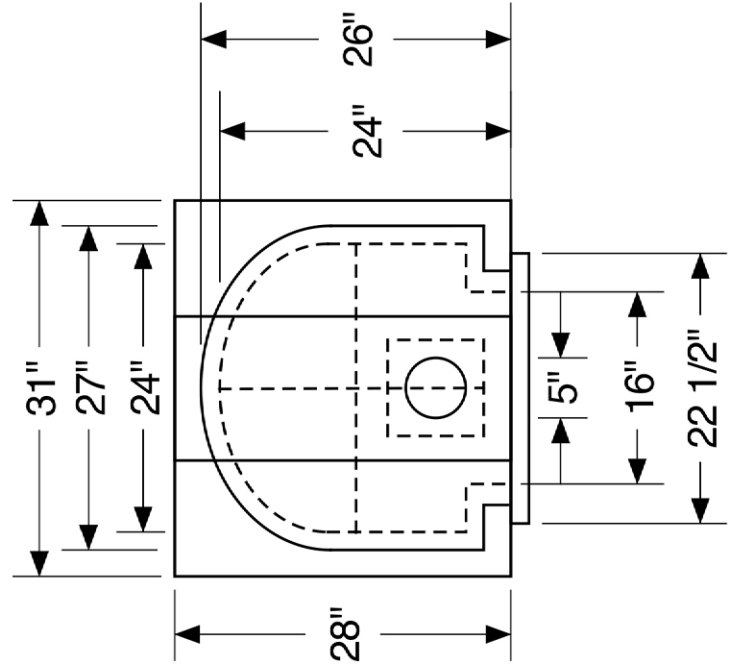
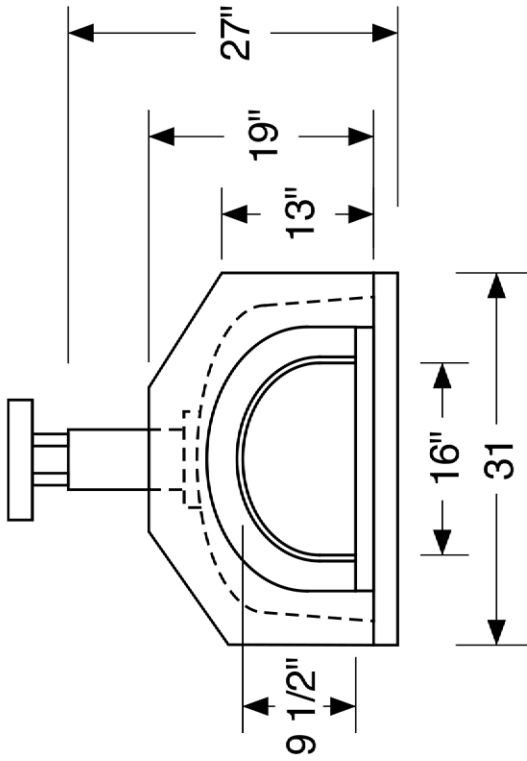

# Strada60

v1.3  
9/12

© Forno Bravo 2012